

# G03 PRO SERIES

Maximum Flow Rate: 11.7 l/min (3.1 USgpm)  
Maximum Pressure: 83 bar (1200 psi) for Metallic Pump Heads  
24 bar (350 psi) for Non-metallic Pump Heads

## **WANNER™ HYDRA-CELL® PRO** SEAL-LESS PUMP TECHNOLOGIES



UK CA CE

*G03 Shaft-driven with Stainless Steel pump head*

### **A higher standard of pump performance and energy efficiency.**

- Integrates **Wanner Hydra-Cell® Pro** seal-less pump technologies for the highest levels of volumetric and energy efficiencies, up to 90% across the full rpm range.
- Reliably handles a wide range of viscosities and shear sensitivities, corrosive liquids, abrasives, slurries and suspended solids.
- No mechanical dynamic seals, packing, or cups to leak, wear or replace – reduces maintenance, costs and downtime.
- Can run dry indefinitely without damage to the pump.
- Seal-less design API 674 pumps that also exceed API 675 standards for accuracy, linearity and repeatability.
- Pumped media is 100% contained – prevents degradation, contamination and environmental risks.
- Patented ADPC (Advanced Diaphragm Position Control) and hydraulic oil management system protect diaphragms under closed or restricted inlet conditions.
- Reduced ownership costs – acquisition, operation, service, maintenance, and energy use.

  
**WANNER™**

# G03 Pro Series | Performance

## Capacities

Model	Max. Input rpm	Max. Flow Capacities @69 bar (1000 psi)		Max. Inlet Pressure				Max. Discharge Pressure					
		l/min	USgpm	Metallic Heads bar	psi	Non-Metallic Heads bar	psi	Metallic Heads bar	psi	Polypropylene bar	psi	PVDF bar	psi
G03-X	1750	11.7	3.1	17	250	17	250	69	1000	17	250	24	350
G03-E*	1750	8.3	2.2	17	250	17	250	83	1200	17	250	24	350

\*Kel-Cell

Performance and specification ratings apply to G03 Kel-Cell and G03 Shaft-driven configurations unless specifically noted otherwise.

## Metering & Dosing

API 675 Performance Characteristics of Steady State Accuracy  $\pm 1\%$ , Linearity  $\pm 3\%$  and Repeatability  $\pm 3\%$  can be achieved at speeds up to 1440 rpm and pressures up to 24 bar (non-metallic pump heads) or up to 69 bar (metallic pump heads) for X-cam pumps only.

- True positive displacement pumping action achieves overall efficiency of  $>90\%$ , targeting improvements at lower speeds and higher pressures.

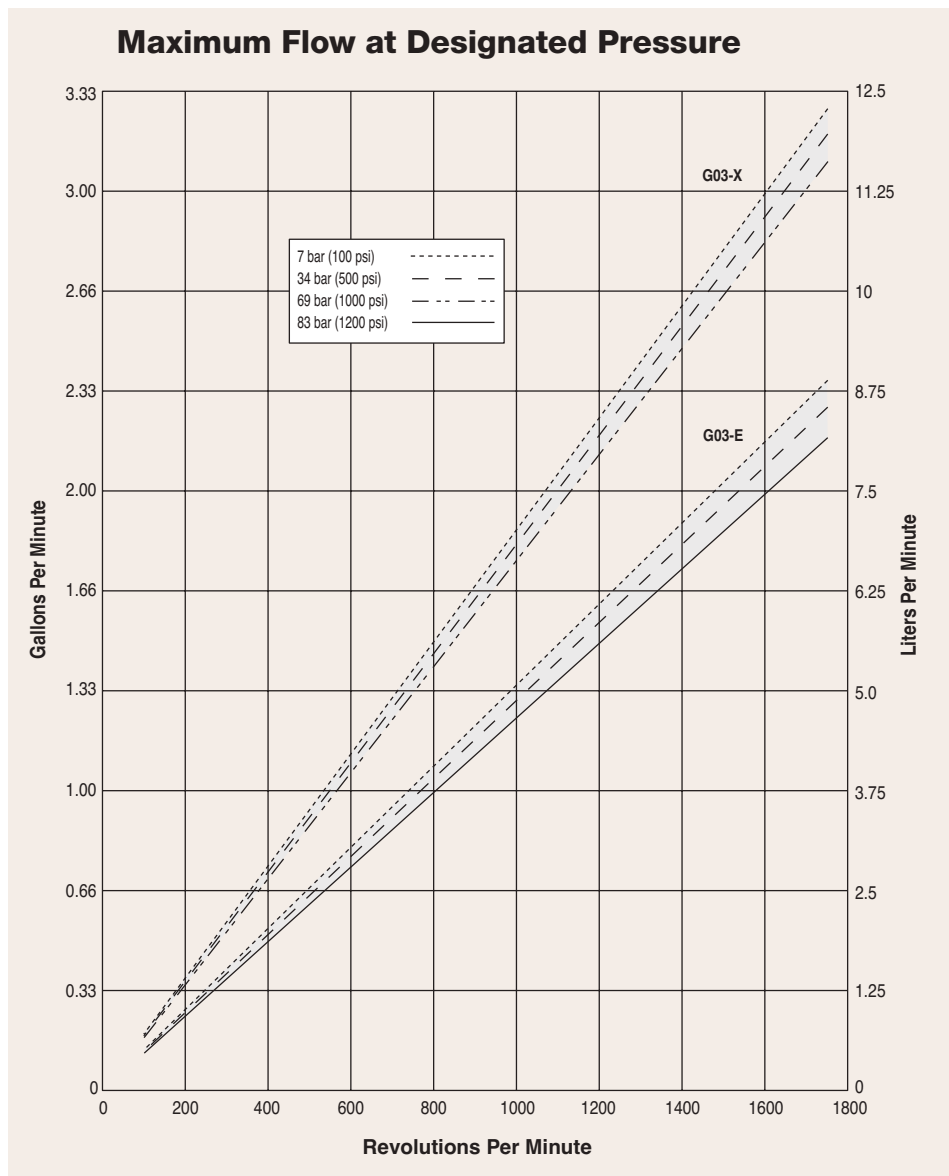

Due to the Wanner Engineering Continuous Improvement Program, specifications and other data are subject to change.

# G03 Pro Series | Specifications

## Flow Capacities @ 69 bar (1000 psi) 4-pole Motor @ 50 Hz

Model	rpm	l/min	USgpm
G03-X	1450	9.7	2.61
G03-E	1450	6.8	1.885

## Flow Capacities @ 69 bar (1000 psi) 6-pole Motor @ 50 Hz

Model	rpm	l/min	USgpm
G03-X	960	6.2	1.64
G03-E	960	4.5	1.18

## Delivery @ 83 bar (1200 psi)

Model	litres/rev	gal/rev
G03-E	0.0046	0.0012

## Delivery @ 69 bar (1000 psi)

Model	litres/rev	gal/rev
G03-X	0.0067	0.0018
G03-E	0.0047	0.0013

## Maximum Discharge Pressure

Metallic Heads: G03-X, E to 69 bar (1000 psi) Kel-Cell  
G03-E to 83 bar (1200 psi) Non-Kel-Cell  
G13 to 69 bar (1000 psi)

Non-metallic Heads: 17 bar (250 psi) Polypropylene  
24 bar (350 psi) PVDF

## Maximum Inlet Pressure

Metallic Heads: 17 bar (250 psi)  
Non-metallic Heads: 17 bar (250 psi)

## Maximum Operating Temperature

Metallic Heads: 121°C (250°F) - Consult factory for correct component selection for temperatures from 71°C (160°F) to 121°C (250°F).

Non-metallic Heads: 60°C (140°F).

## Maximum Solids Size 200 microns

## Calculating Required Power

$$\frac{6 \times \text{rpm}}{63,000} + \frac{\text{gpm} \times \text{psi}}{1,460} = \text{electric motor hp}$$

$$\frac{6 \times \text{rpm}}{84,428} + \frac{\text{l/min} \times \text{bar}}{511} = \text{electric motor kW}$$

### Attention!

When using a variable frequency drive (VFD) controller, calculate the hp or kW at minimum and maximum pump speed to ensure the correct hp or kW motor is selected. Note that motor manufacturers typically de-rate the service factor to 1.0 when operating with a VFD.

## Calculating Pulley Size

$$\frac{\text{motor pulley OD}}{\text{pump rpm}} = \frac{\text{pump pulley OD}}{\text{motor rpm}}$$

Due to the Wanner Engineering Continuous Improvement Program, specifications and other data are subject to change.

## Inlet Port

1/2 inch BSPT  
1/2 inch NPT  
300lb ANSI RF Flange  
PN40 DN20 DIN Flange

## Discharge Port

3/8 inch BSPT  
3/8 inch NPT  
600lb ANSI RF Flange  
PN100 DN15 DIN Flange

## Shaft Diameter

G13: 24 mm (0.945 inch) hollow shaft  
G03: 22.2 mm (7/8 inch)

## Shaft Rotation

Reverse (bi-directional)

## Bearings

Precision ball bearings

## Oil Capacity

0.95 litres (1.0 US quart)

## Weight

Metallic Heads: 12.7 kg (28 lbs.)

Non-metallic Heads: 8.6 kg (19 lbs.)

## Net Positive Suction Head (NPSHr)

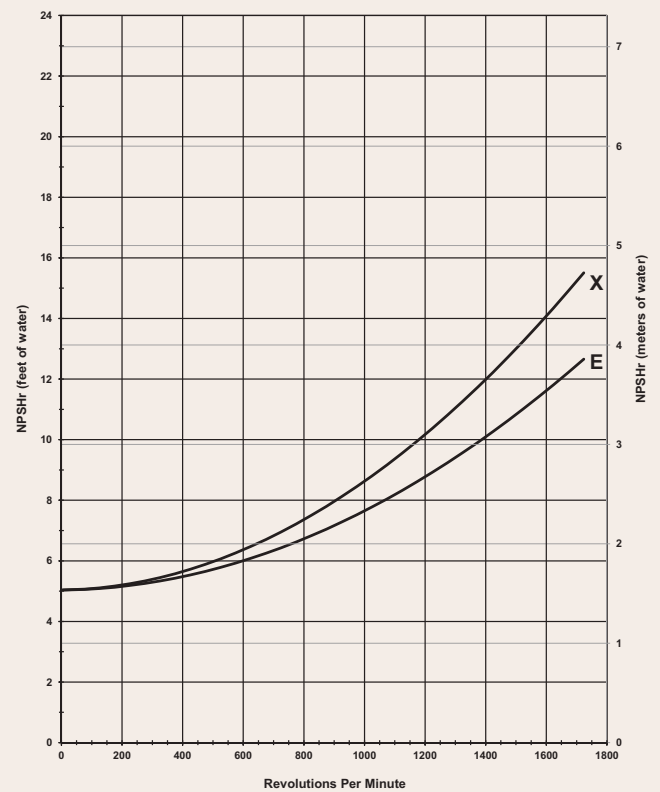

## Suction Lift

Each Hydra-Cell pump has different lift capability depending on model size, cam angle, speed, and fluid characteristics. To ensure that your specific lift characteristics are met, refer to the inlet calculations regarding friction, and acceleration head losses in your Hydra-Cell Product Manual. Compare those calculations to the NPSHr curves above.

## G03 Baseplate Assembly with Motor for IEC 90 Motor Frame

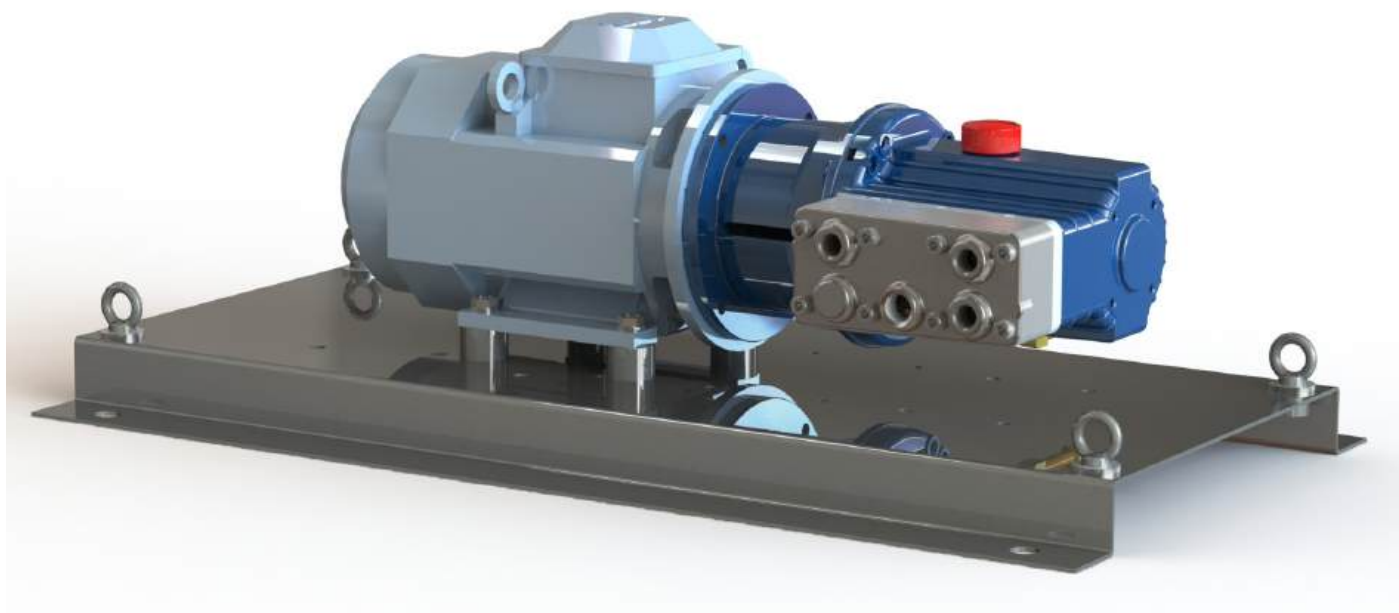

Dimensions in mm

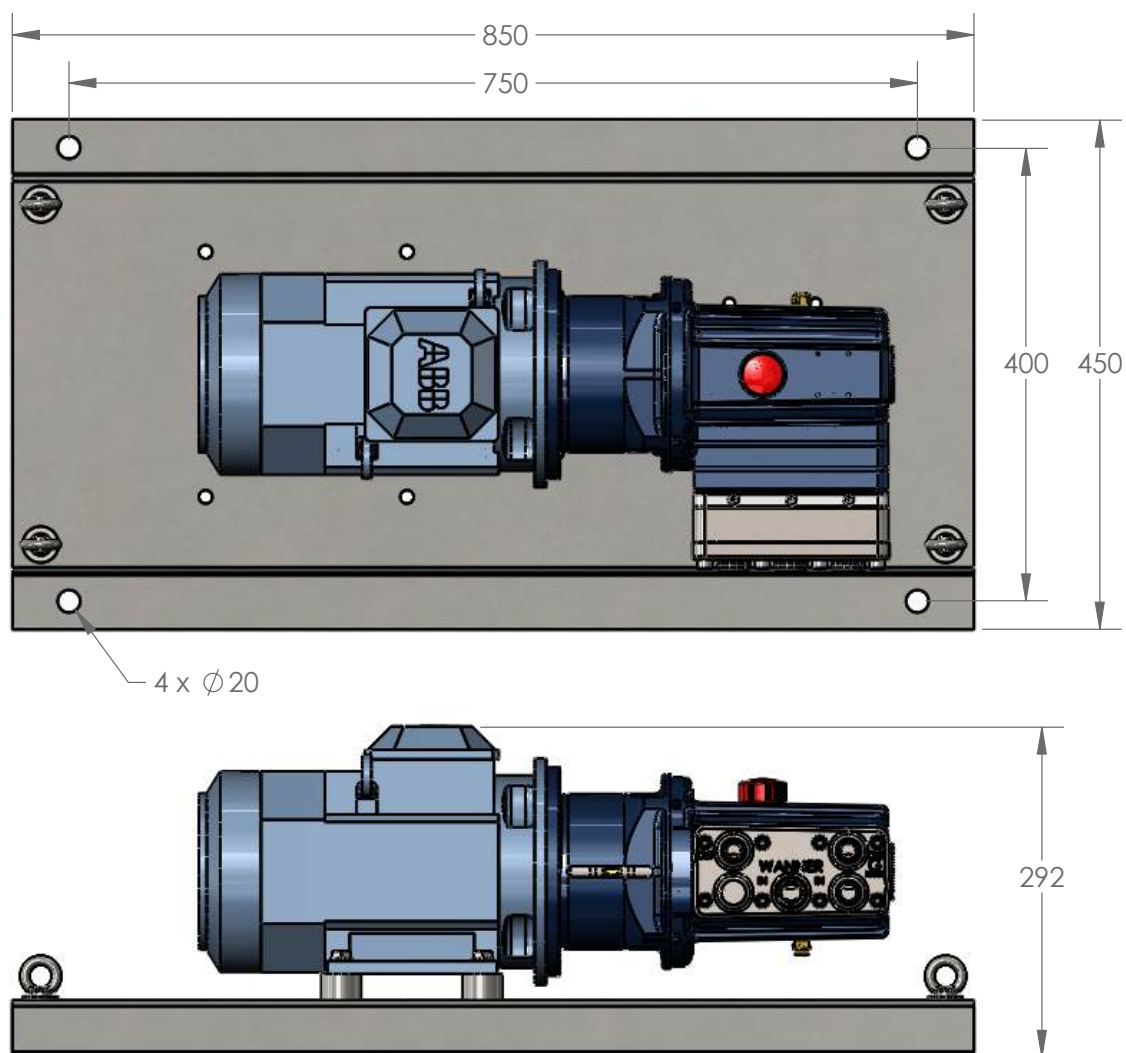

## G03 Baseplate Assembly with Motor Adaptor for IEC 100 Motor Frame

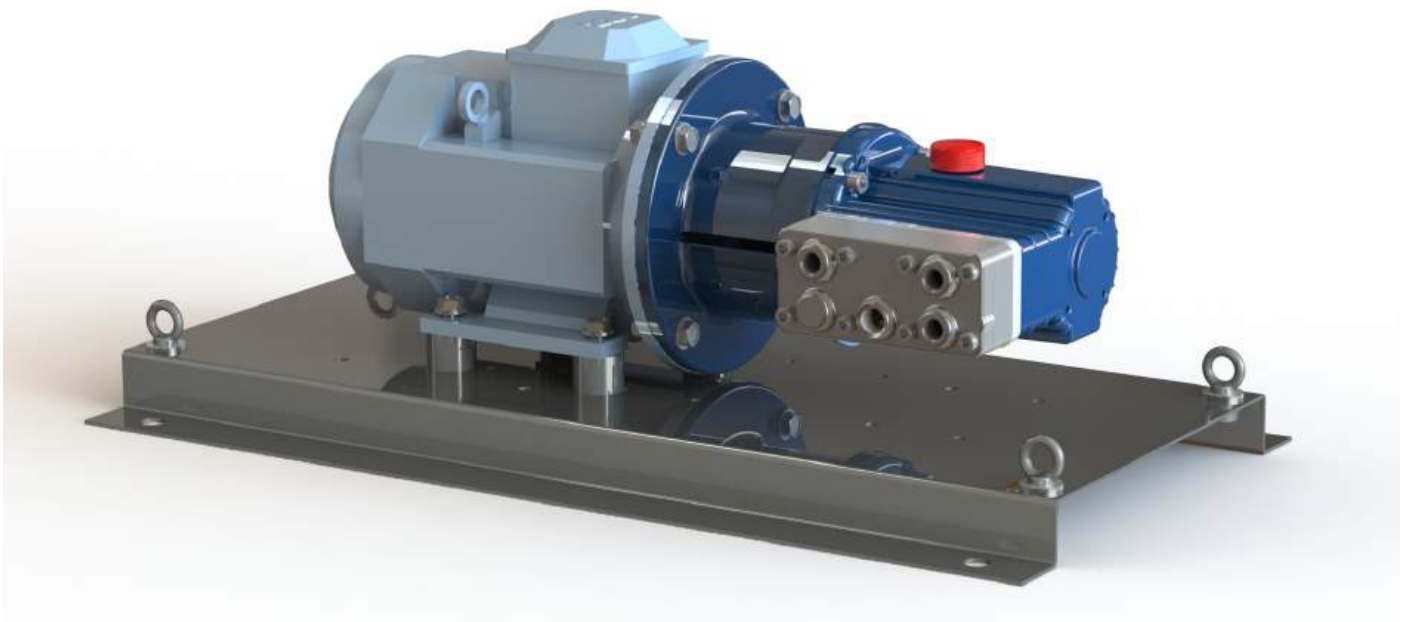

Dimensions in mm

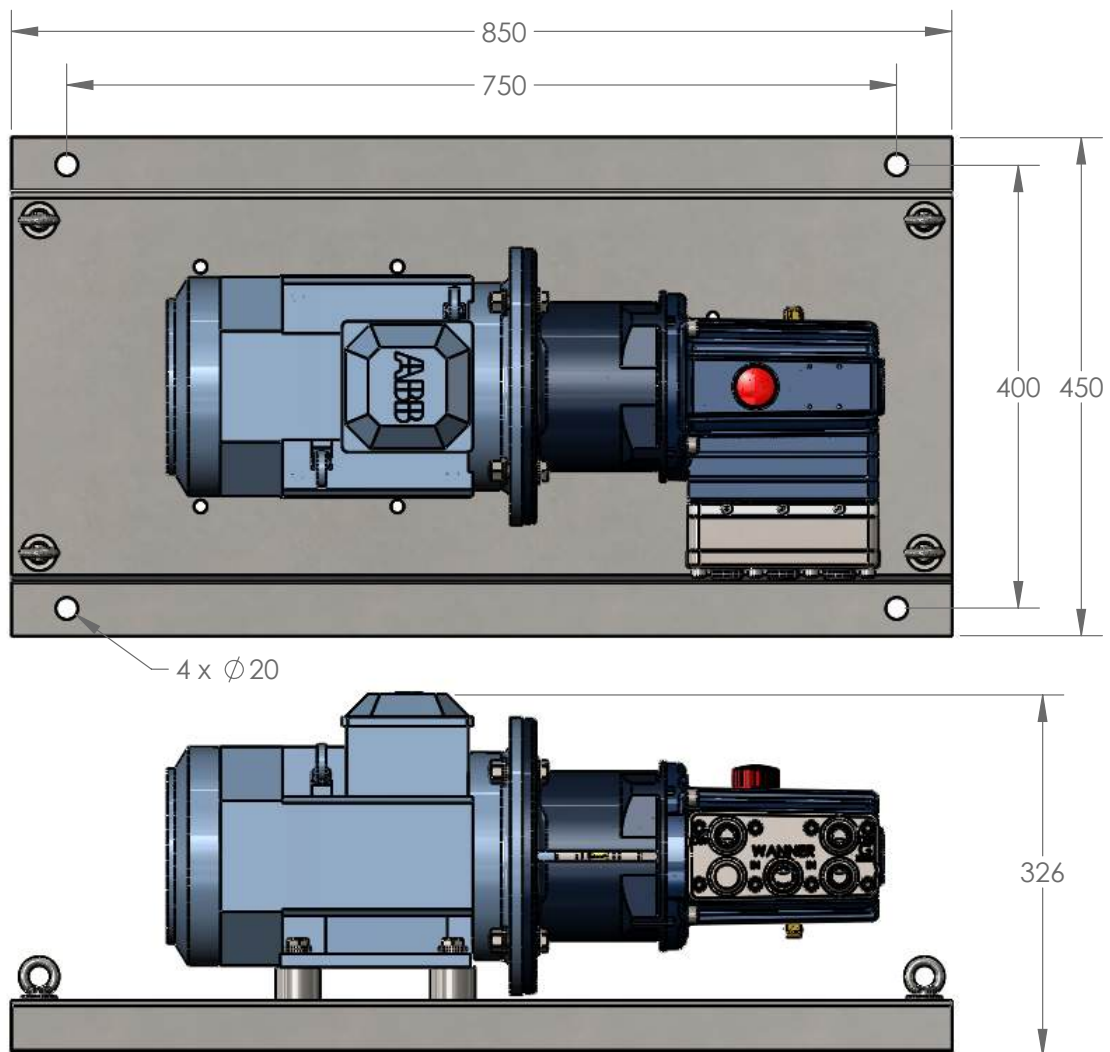

## G03 Baseplate Assembly with Motor Adaptor for IEC 132 Motor Frame

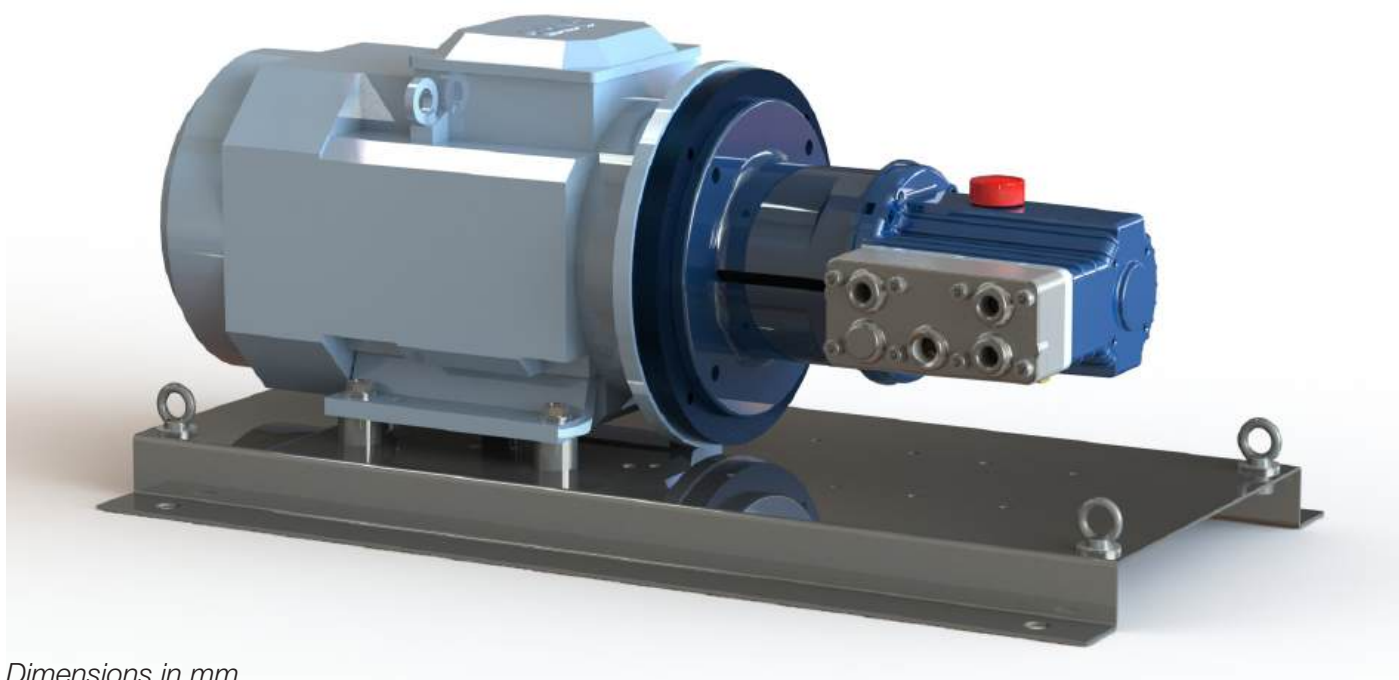

Dimensions in mm

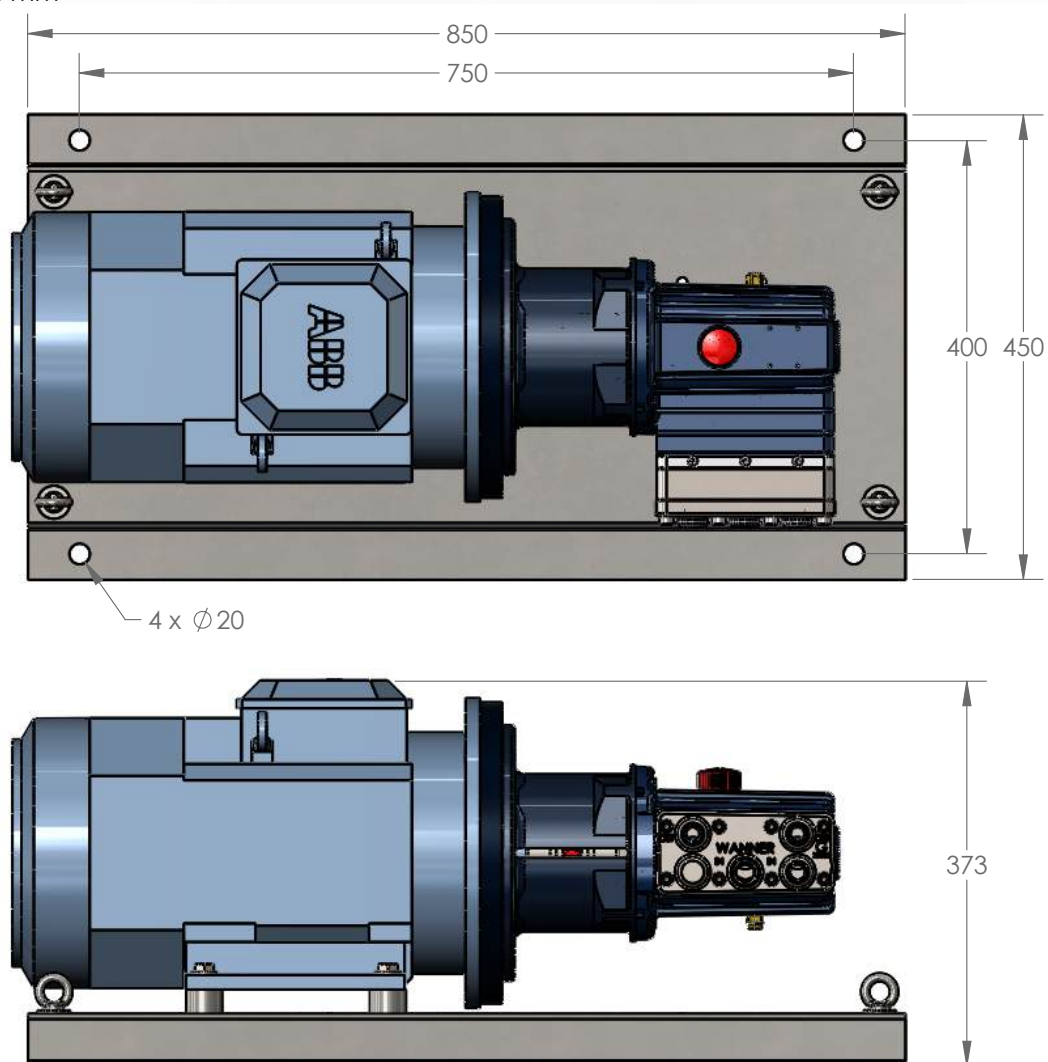

## G13 Baseplate Assembly with Motor Adaptor for IEC 90 & IEC 80 Motor Frame

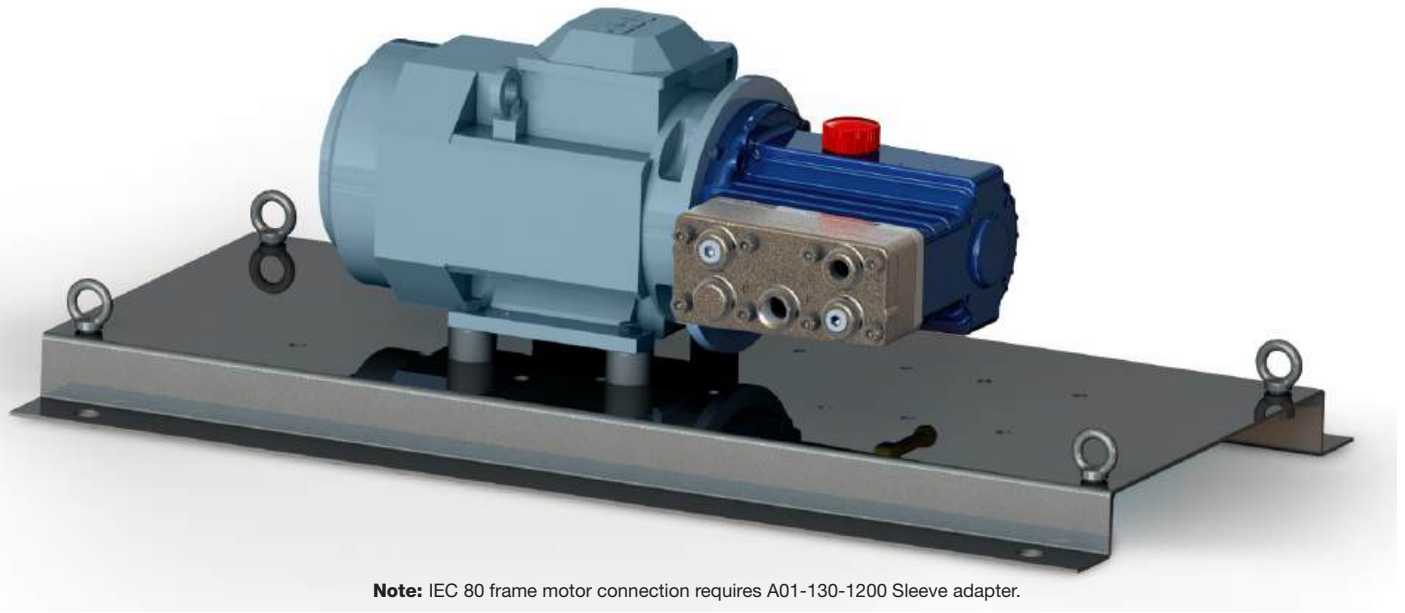

**Note:** IEC 80 frame motor connection requires A01-130-1200 Sleeve adapter.

*Dimensions in mm*

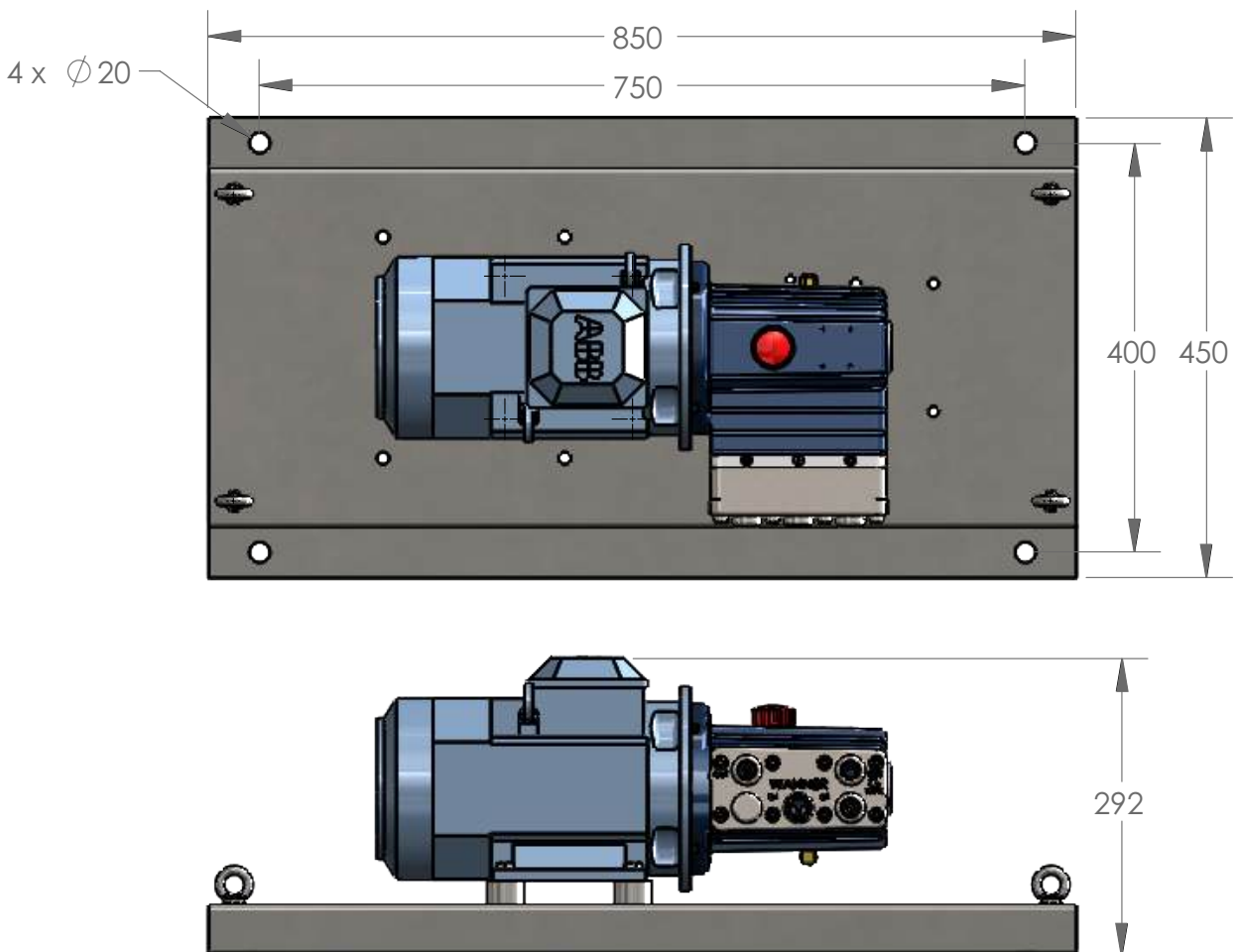

## G13 Models with Metallic Pump Head mm (Inches)

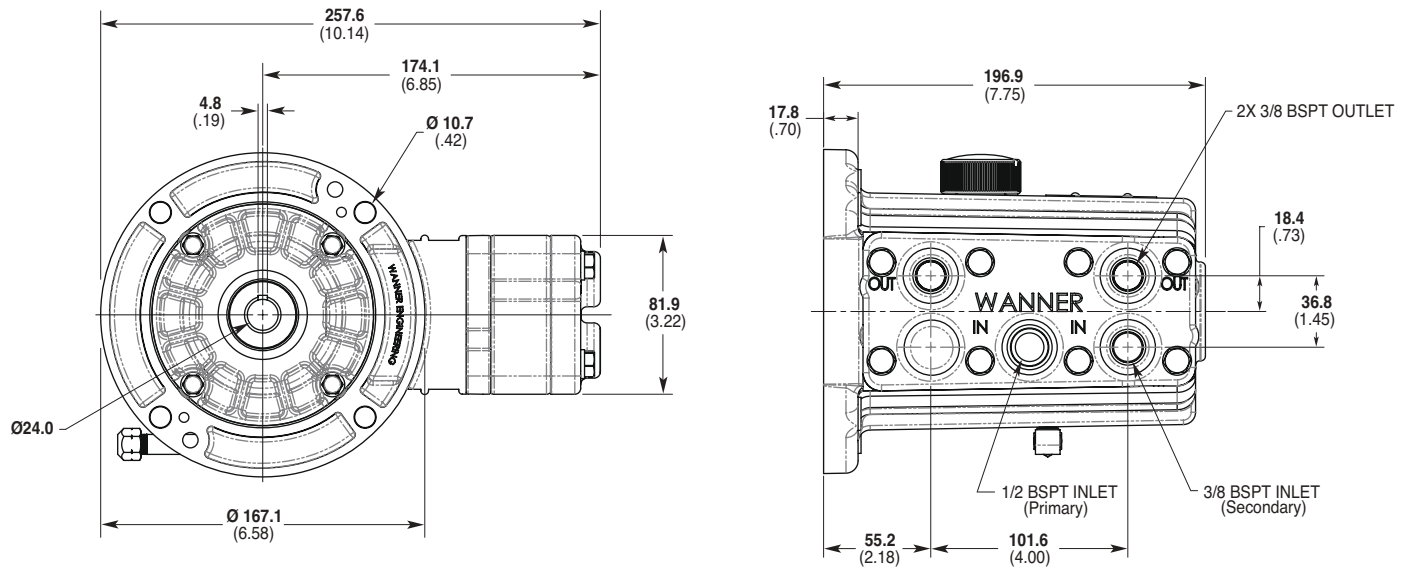

## G03 Models with Non-metallic Pump Head mm (Inches)

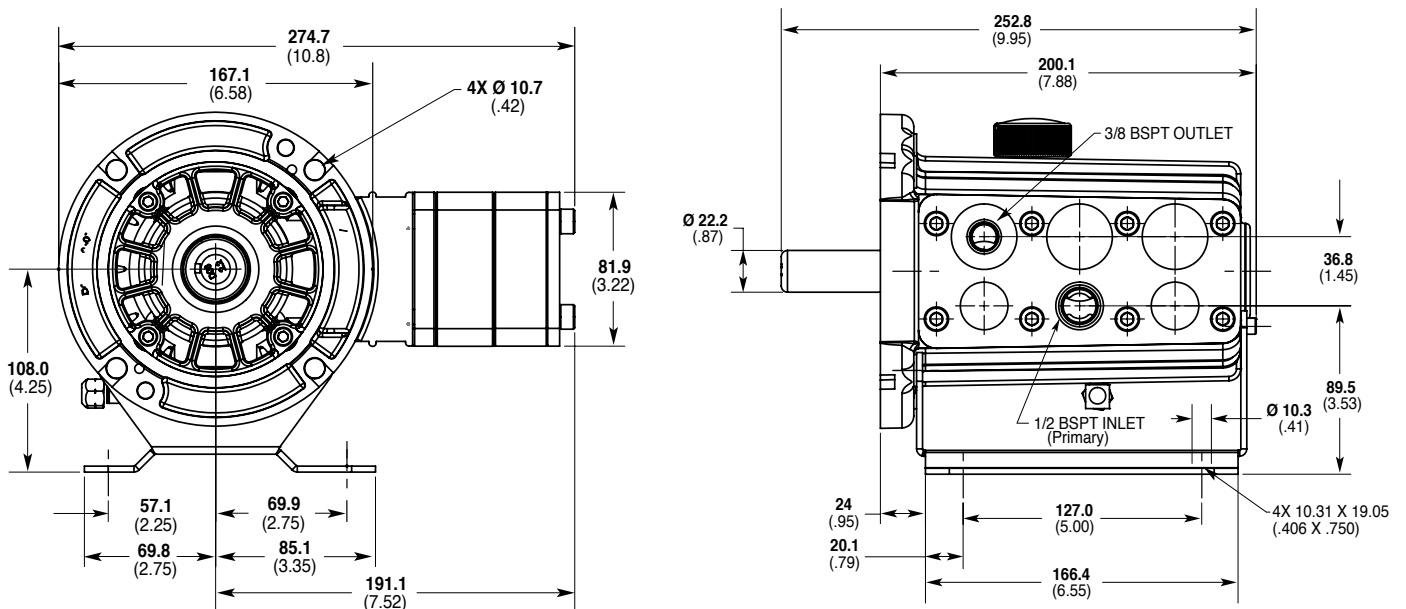

**Note:** Dimensions are for reference only. Contact factory for certified drawings.



# G03 Pro Series | Representative Drawings

## G03 Models with ANSI RF Flanges mm (Inches)

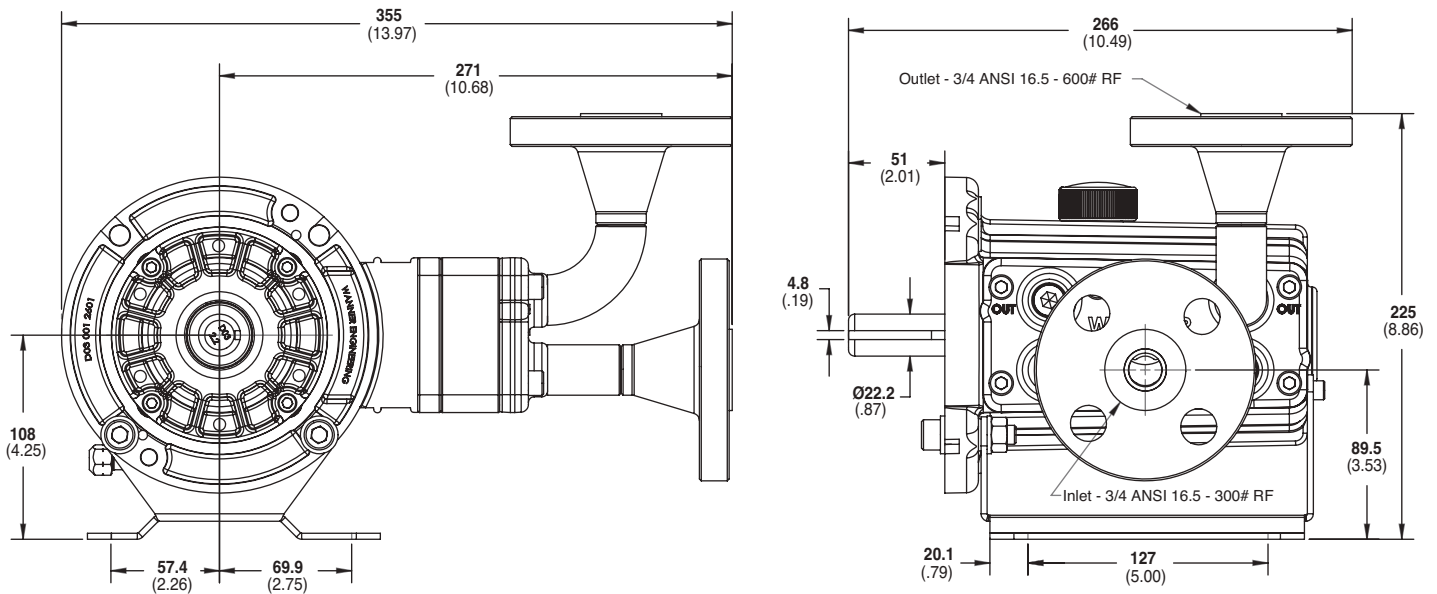

## G03 Models with DIN Flanges mm (Inches)

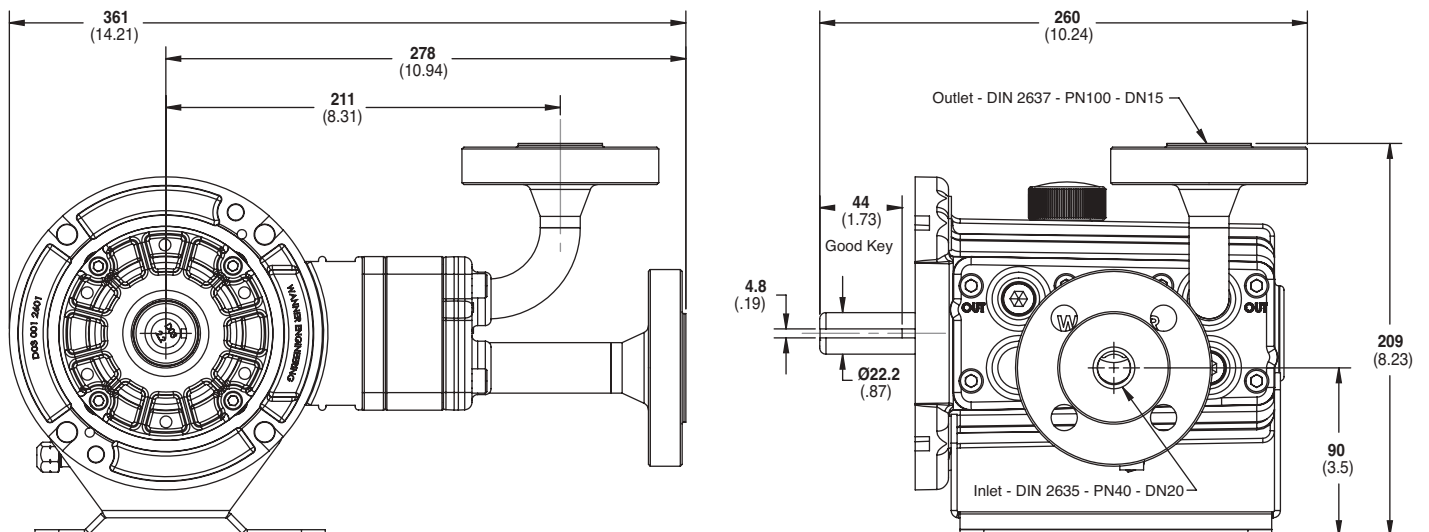

**Note:** Dimensions are for reference only. Contact factory for certified drawings.

## Pump/Motor Adapter mm (Inches)

### Part Number: A04-003-1202

Must be ordered separately for G03 models for use with IEC 80 - 90 frame motors, B5 flange.

*NEMA adaptor available - consult factory.*

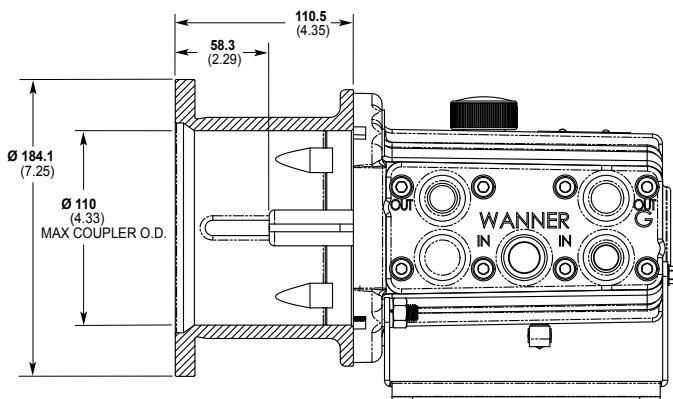

### Part Number: A04-004-1202

Must be ordered separately for G03 models for use with IEC 100 - 112 frame motors, B5 flange.

*NEMA adaptor available - consult factory.*

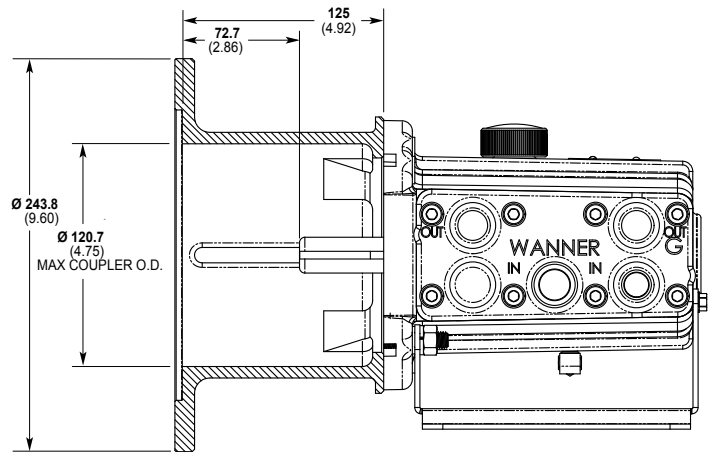

## Valve Selection

A Hydra-Cell G03 pumping system uses a **C46 Pressure Regulating Valve**.



# G03 Pro Series | Options

## Contact Wanner International for:

- Motors, bases, couplings and other pump accessories
- Hydra-Oil selection and specification information
- Design considerations, installation guidelines, and other technical assistance in pump selection
- Process liquid end built with NACE and 3.1 traceable material certification



*G13 Close-coupled with Brass pump head*



*G13 Close-coupled with Polypropylene pump head*



*G03 with Stainless Steel pump head and ANSI RF flanges*



*G03 Shaft-driven with Stainless Steel pump head*

## Ordering Information

A complete G03 Pro Series Model Number contains 12 digits including 9 customer-specified design and materials options, for example: G03EMBPSFEPG.

1	2	3	4	5	6	7	8	9	10	11	12
G		3		K							

Digit	Order Code	Description
<b>1-3</b>		<b>Pump Configuration</b>
	<b>G03</b>	Shaft-driven (BSPT Ports)*
	<b>G13</b>	Close-coupled to IEC 90 footed motor (BSPT Ports) *Pump/motor adapters ordered separately. See page 11.
<b>4</b>		<b>Hydraulic End Cam</b>
	<b>X</b>	Max 9.7 l/min (2.6 USgpm) @ 1450 rpm
	<b>E</b>	Max 6.8 l/min (1.8 USgpm) @ 1450 rpm
<b>5</b>		<b>Pump Head Version</b>
	<b>K</b>	Kel-Cell BSPT Ports (X & E cams) <i>See lower right for ATEX Certification Kit Options.</i>
<b>6</b>		<b>Pump Head Material</b>
	<b>B</b>	Brass
	<b>M</b>	PVDF
	<b>P</b>	Polypropylene
	<b>R</b>	316L Stainless Steel with ANSI RF Flanges, Class 300lb x 600lb
	<b>1</b>	316L Stainless Steel with DIN Flanges, Class PN40 DN20 x PN100 DN15♦
	<b>S</b>	316L Stainless Steel
	<b>T</b>	Hastelloy CW12MW ♦ Selecting this option will result in a Wanner International generated Pump Code, stamped onto the pump.
<b>7</b>		<b>Diaphragm &amp; O-ring Material</b>
	<b>A</b>	Aflas diaphragm / PTFE o-ring
	<b>E</b>	EPDM (requires EPDM-compatible oil - Digit 12 oil code J)
	<b>G</b>	FKM
	<b>J</b>	PTFE
	<b>P</b>	Neoprene
	<b>T</b>	Buna-N
<b>8</b>		<b>Valve Seat Material</b>
	<b>C</b>	Ceramic
	<b>D</b>	Tungsten Carbide
	<b>H</b>	17-4 Stainless Steel
	<b>S</b>	316L Stainless Steel
	<b>T</b>	Hastelloy C

Digit	Order Code	Description
<b>9</b>		<b>Valve Material</b>
	<b>C</b>	Ceramic
	<b>D</b>	Tungsten Carbide
	<b>F</b>	17-4 Stainless Steel
	<b>N</b>	Nitronic 50
	<b>T</b>	Hastelloy C
<b>10</b>		<b>Valve Springs</b>
	<b>E</b>	Elgiloy
	<b>T</b>	Hastelloy C
<b>11</b>		<b>Valve Spring Retainers</b>
	<b>C</b>	Celcon
	<b>H</b>	17-7 Stainless Steel (used with metallic heads only)
	<b>M</b>	PVDF
	<b>P</b>	Polypropylene
	<b>T</b>	Hastelloy C (used with metallic heads only)
	<b>Y</b>	Nylon
<b>12</b>		<b>Hydra-Oil</b>
	<b>A</b>	10W30 standard-duty oil
	<b>G</b>	5W30 cold-temp severe-duty synthetic oil
	<b>J</b>	20-wt EPDM-compatible oil
	<b>K</b>	Food-contact oil



### ATEX Certification Kit Options

As a separate line on your order, please add the required ATEX Certification Kit Option.

- ATEX 2014/34/EU Certified, Category 2, Zone 1
- ATEX 2014/34/EU Certified, Category 3, Zone 2

- All options include Certificate, Oil Level Monitor or Sight Glass, Earth Stud & Secondary ATEX Label.
- Extra oil is required to fill the oil bowl during installation of ATEX pumps. This oil is not included and must be ordered separately.
- ATEX is not available with non-metallic pump heads.

## Partners in over 70 countries



**WANNER™**  
Global Sales and Technical Support



### Americas

-  Minneapolis, Minnesota USA
-  Wichita Falls, Texas USA
-  São Paulo, Brazil
-  Buenos Aires, Argentina

### EMEA | Australia

-  Hampshire, United Kingdom
-  Cairo, Egypt
-  Düsseldorf, Germany
-  Lyon, France

### Asia | Pacific

-  Kowloon, Hong Kong
-  Shanghai, China
-  Jakarta, Indonesia

### India

-  Mumbai, India
-  New Delhi
-  Bangalore
-  Gujarat

## Wanner worldwide

GLOBAL SALES & TECHNICAL SUPPORT

### WANNER ENGINEERING, INC.

WORLD HEADQUARTERS & MANUFACTURING

Minneapolis, Minnesota USA  
t: 612-332-5681  
e: sales@wannereng.com  
Hydra-Cell.com

### REGIONAL OFFICE

Wichita Falls, Texas USA  
t: 940-322-7111  
e: sales@wannereng.com

### LATIN AMERICAN OFFICE

São Paulo, Brazil  
t: +55 (11) 99582-1969  
e: mmagoni@wannereng.com  
Hydra-Cell-Pumps.com.br

### WANNER INTERNATIONAL, LTD.

UNITED KINGDOM

Church Crookham, Hampshire UK  
t: +44 (0) 1252 816847  
e: support@wannerint.com  
Hydra-Cell.co.uk

### WANNER PUMPS, LTD.

Kowloon, HONG KONG  
t: +852 3428 6534  
e: sales@wannerpumps.com  
WannerPumps.com

Shanghai, CHINA  
t: +86-21-6876 3700  
e: sales@wannerpumps.com  
WannerPumps.com

### WANNER INDIA PVT. LTD.

Mumbai, INDIA  
t: +91 (22) 22044766  
e: support@wannerindia.com  
WannerIndia.com



### OFFICIAL UK DISTRIBUTOR

Michael Smith Engineers Limited  
Web: www.michael-smith-engineers.co.uk  
Email: info@michael-smith-engineers.co.uk  
Freephone: 0800 316 7891