

G04 PRO SERIES

Maximum Flow Rate: 11.2 l/min (2.9 USgpm)

Maximum Pressure: 172 bar (2500 psi) for Metallic Pump Heads

WANNER™ HYDRA-CELL® PRO SEAL-LESS PUMP TECHNOLOGIES



G04 with Stainless Steel pump head

A higher standard of pump performance and energy efficiency.

- Integrates **Wanner Hydra-Cell® Pro** seal-less pump technologies for the highest levels of volumetric and energy efficiencies, up to 90% across the full rpm range.
- Reliably handles a wide range of viscosities and shear sensitivities, corrosive liquids, abrasives, slurries and suspended solids.
- No mechanical dynamic seals, packing, or cups to leak, wear or replace – reduces maintenance, costs and downtime.
- Can run dry indefinitely without damage to the pump.
- Seal-less design API 674 pumps that also exceed API 675 standards for accuracy, linearity and repeatability.
- Pumped media is 100% contained – prevents degradation, contamination and environmental risks.
- Reduced ownership costs – acquisition, operation, service, maintenance, and energy use.
- Valve set design and material options reliably handle a wide range of viscosities and shear sensitivities, plus corrosive liquids, abrasives, slurries and particulates.

G04 Pro Series | Performance

Capacities

Model	Max. Input rpm	Max. Flow Capacities		Max. Inlet Pressure		Max. Discharge Pressure	
		l/min	USgpm	bar	psi	bar	psi
G04-X	1750	11.2	2.9	34	500	172	2500
G04-E	1750	7.7	2.0	34	500	172	2500

Performance and specification ratings apply to G04 configurations unless specifically noted otherwise.

Metering & Dosing

API 675 Performance Characteristics of Steady State Accuracy $\pm 1\%$, Linearity $\pm 3\%$ and Repeatability $\pm 3\%$ can be achieved at speeds up to 1440 rpm and pressures up to 172 bar (metallic pump heads) for X-cam pumps only.

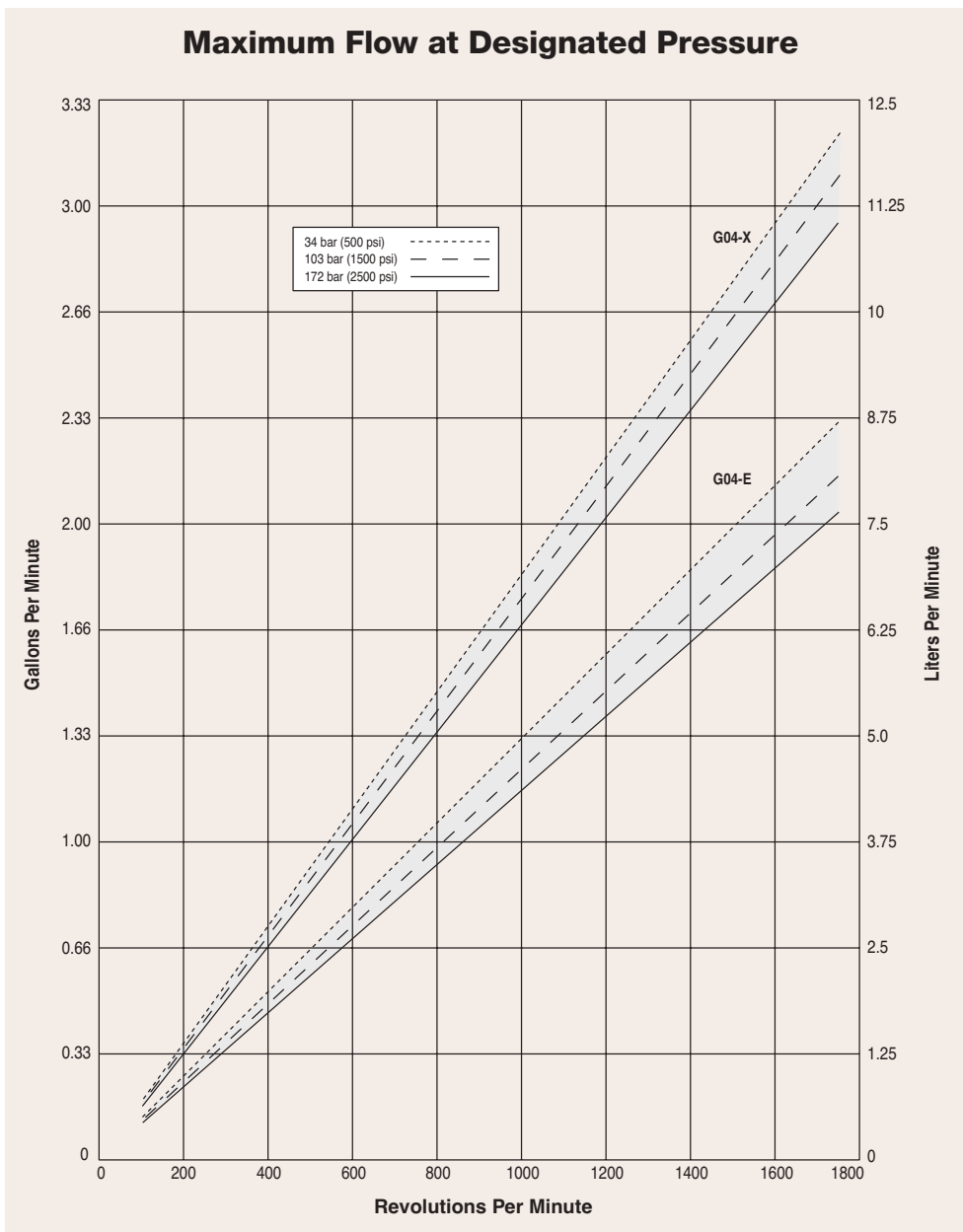

- True positive displacement pumping action achieves overall efficiency of $>90\%$, targeting improvements at lower speeds and higher pressures.

Due to the Wanner Engineering Continuous Improvement Program, specifications and other data are subject to change.

G04 Pro Series | Specifications

Flow Capacities @ 172 bar (2500 psi) 4-pole Motor @ 50 Hz

Model	rpm	l/min	USgpm
G04-X	1450	9.28	2.45
G04-E	1450	6.38	1.74

Flow Capacities @ 172 bar (2500 psi) 6-pole Motor @ 50 Hz

Model	rpm	l/min	USgpm
G04-X	960	6.14	1.63
G04-E	960	4.22	1.15

Delivery

Model	gal/rev		
	@34 bar (500 psi)	@103 bar (1500 psi)	@172 bar (2500 psi)
G04-X	0.0019	0.0018	0.0017
G04-E	0.0013	0.0012	0.0012

Model	litres/rev		
	@34 bar (500 psi)	@103 bar (1500 psi)	@172 bar (2500 psi)
G04-X	0.0070	0.0067	0.0064
G04-E	0.0050	0.0047	0.0044

Maximum Discharge Pressure

Metallic Heads: 172 bar (2500 psi)

Maximum Inlet Pressure

34 bar (500 psi)

Maximum Operating Temperature

Metallic Heads: 121°C (250°F) - Consult factory for correct component selection for temperatures from 71°C (160°F) to 121°C (250°F).

Calculating Required Power

$$\frac{6 \times \text{rpm}}{63,000} + \frac{\text{gpm} \times \text{psi}}{1,460 - \left(\frac{\text{psi} - 500}{20}\right)} = \text{electric motor hp}^*$$

$$\frac{6 \times \text{rpm}}{84,428} + \frac{\text{l/min} \times \text{bar}}{511 - \left(\frac{\text{bar} - 35}{4}\right)} = \text{electric motor kW}^*$$

*rpm equals pump shaft rpm. HP/kW is required application power. Use caution when sizing motors with variable speed drives.

Attention!

When using a variable frequency drive (VFD) controller, calculate the hp or kW at minimum and maximum pump speed to ensure the correct hp or kW motor is selected. Note that motor manufacturers typically de-rate the service factor to 1.0 when operating with a VFD.

Calculating Pulley Size

$$\frac{\text{motor pulley OD}}{\text{pump rpm}} = \frac{\text{pump pulley OD}}{\text{motor rpm}}$$

Maximum Solids Size 200 microns

Inlet Port	1/2 inch BSPT
	1/2 inch NPT
	600lb ANSI RF Flange

Discharge Port	1/2 inch BSPT
	1/2 inch NPT 2500lb ANSI RF Flange

Shaft Diameter 22.2 mm (7/8 inch)

Shaft Rotation Reverse (bi-directional)

Bearings Precision ball bearings

Oil Capacity 1.05 litres (1.1 US quarts)

Weight 16.8 kg (37 lbs.)

Net Positive Suction Head (NPSHr)

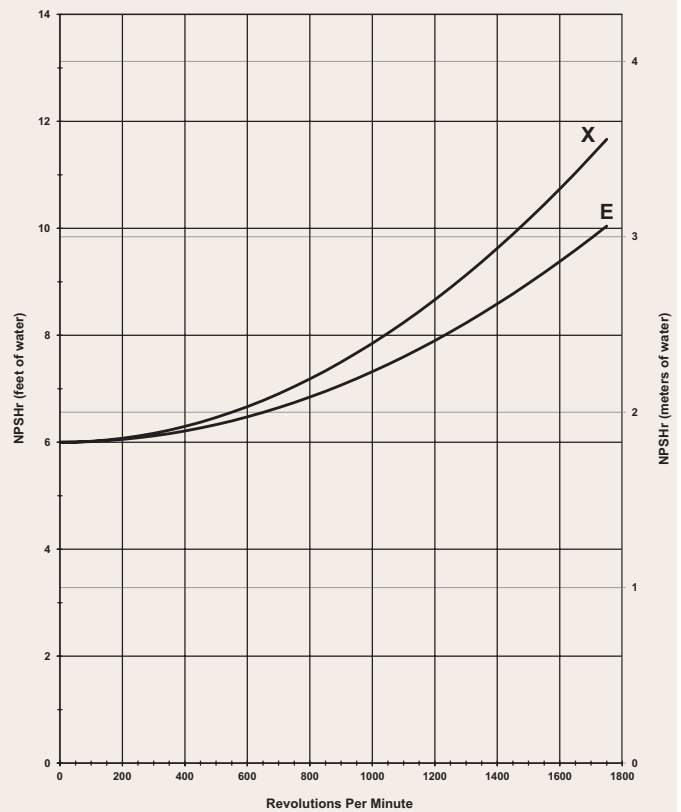

Suction Lift

Each Hydra-Cell pump has different lift capability depending on model size, cam angle, speed, and fluid characteristics. To ensure that your specific lift characteristics are met, refer to the inlet calculations regarding friction, and acceleration head losses in your Hydra-Cell Product Manual. Compare those calculations to the NPSHr curves above.

Due to the Wanner Engineering Continuous Improvement Program, specifications and other data are subject to change.

Baseplate Assembly with Motor Adaptor for IEC 100 Motor Frame

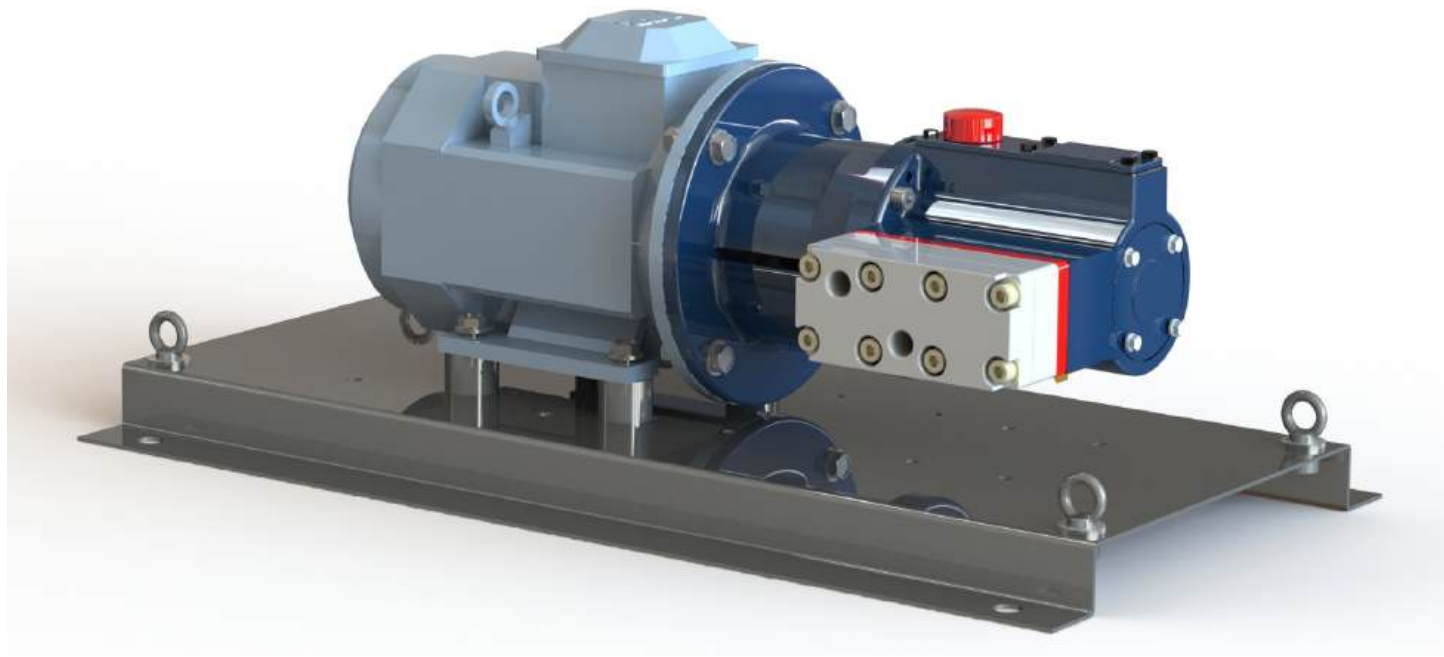

Dimensions in mm

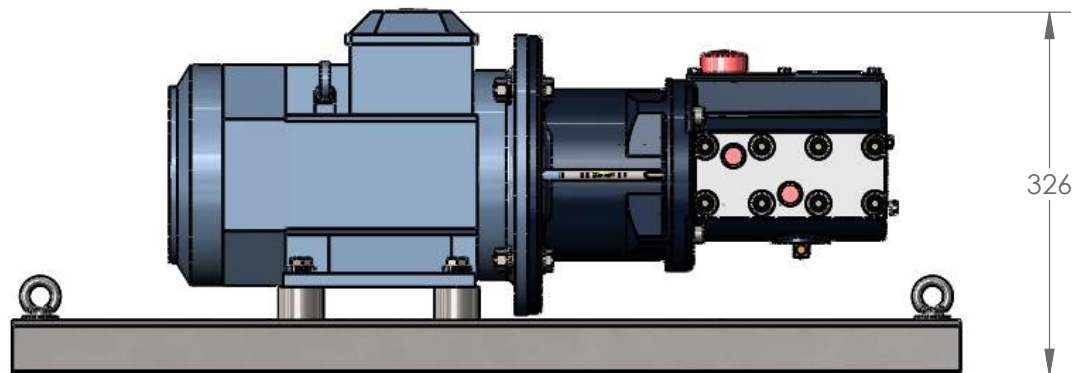
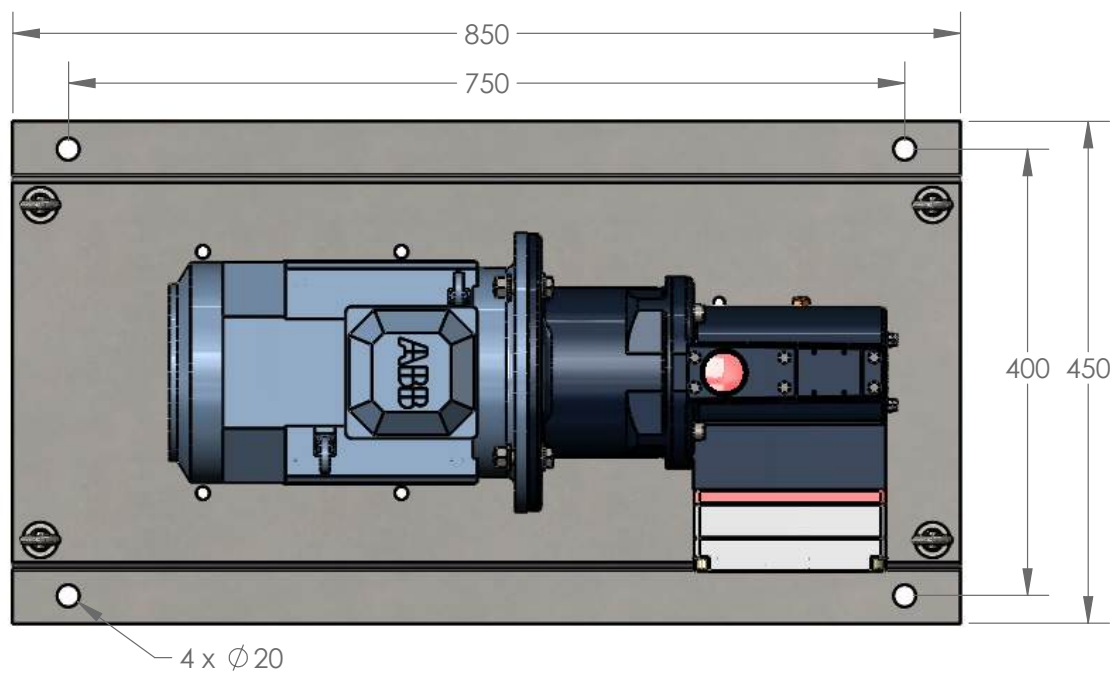

Baseplate Assembly with Motor Adaptor for IEC 132 Motor Frame

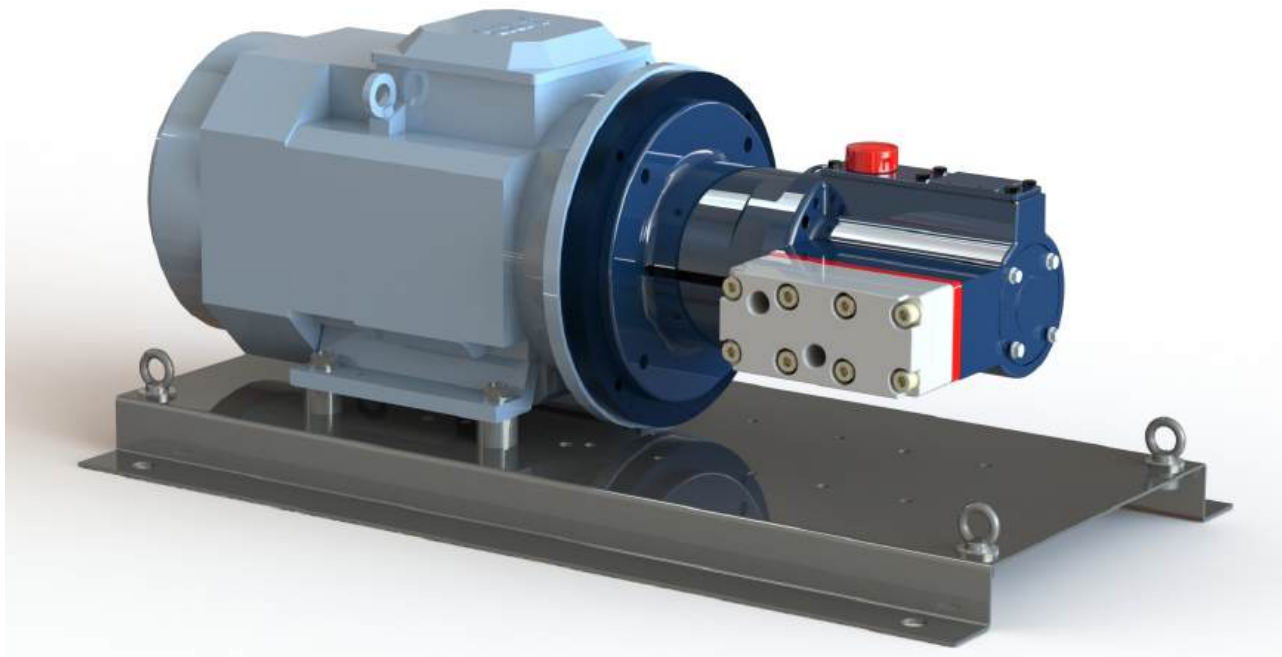

Dimensions in mm

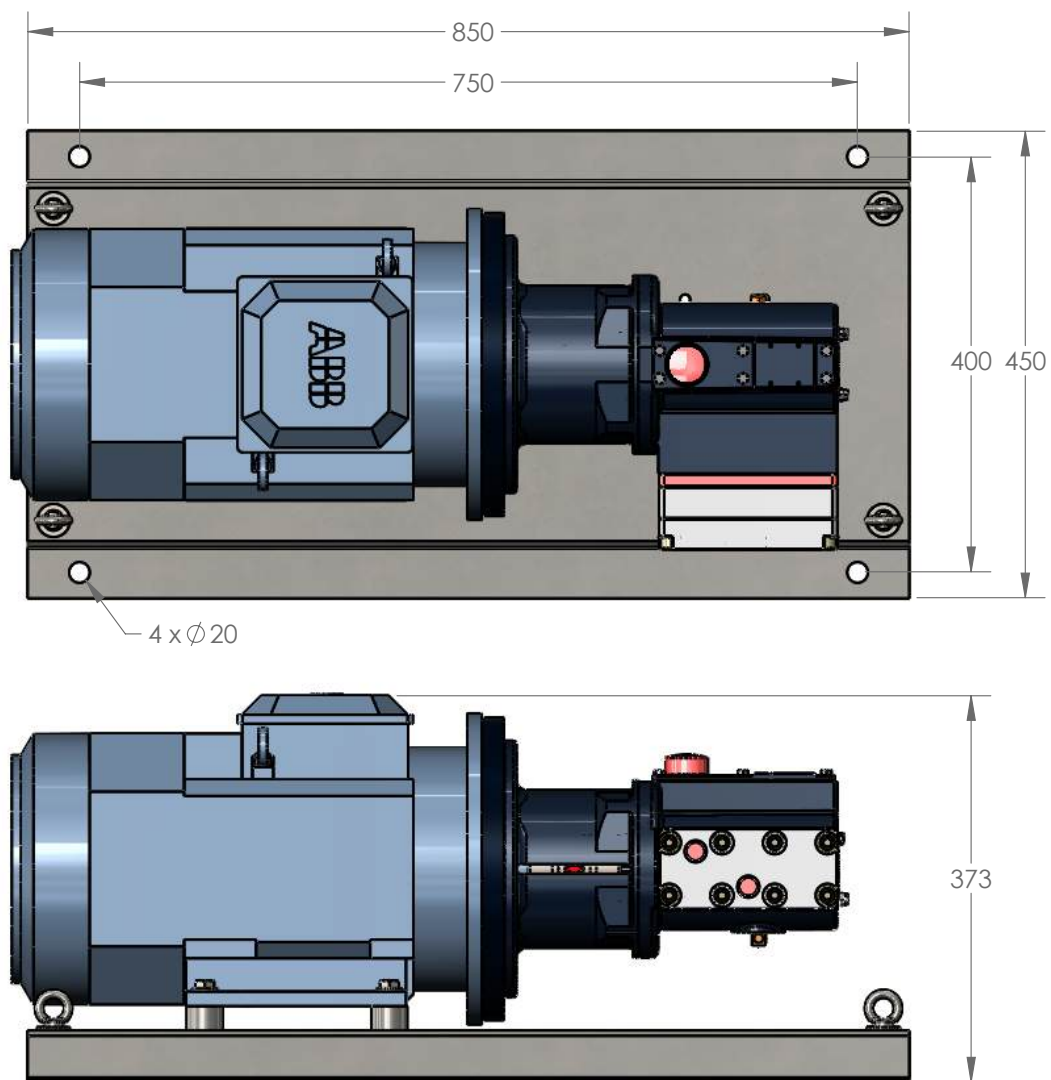

G04 Pro Series | Representative Drawings

G04 Models with Metallic Pump Head mm (Inches)

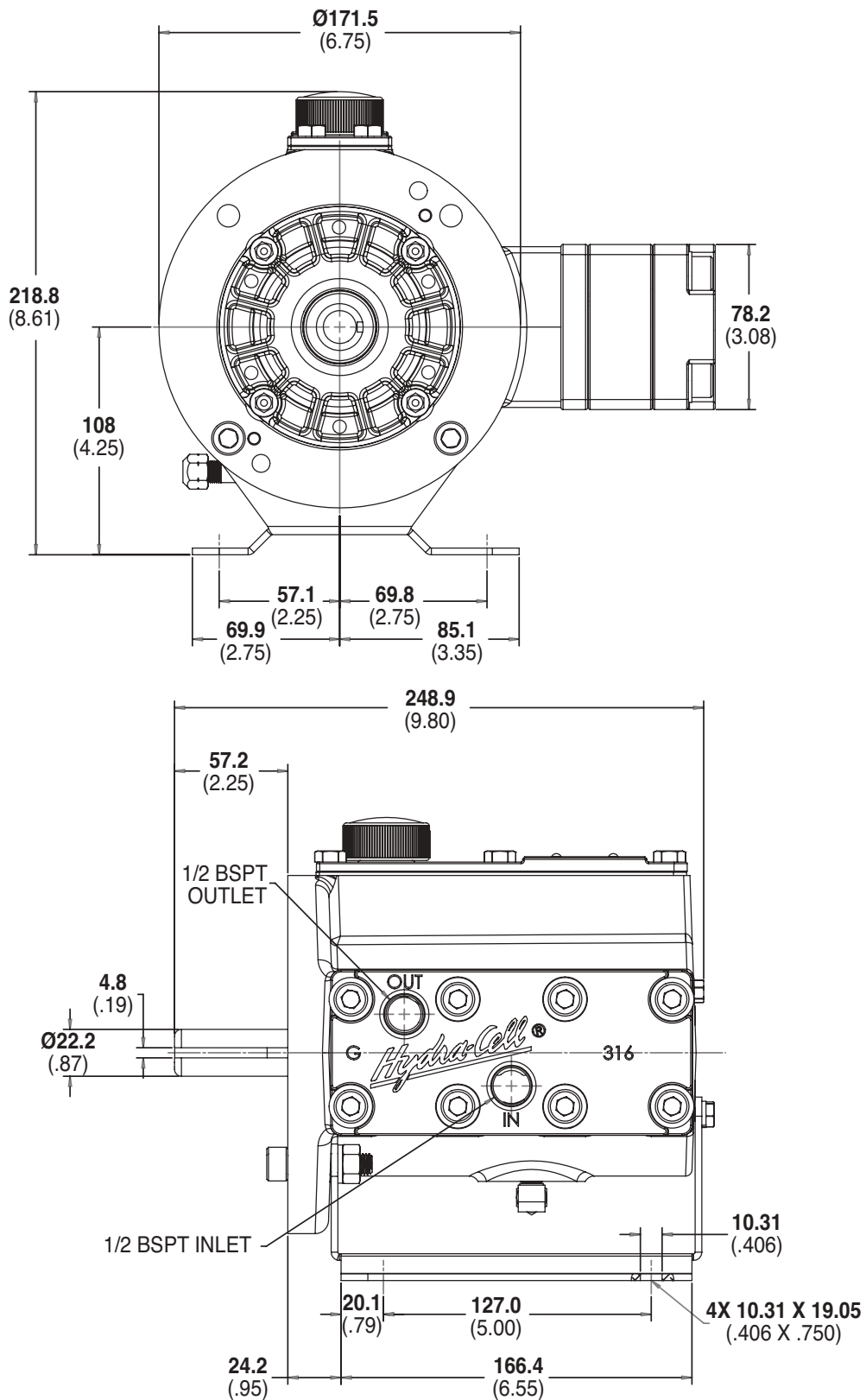

Note: Dimensions are for reference only. Contact factory for certified drawings.

G04 Models with ANSI RF Flanges mm (Inches)

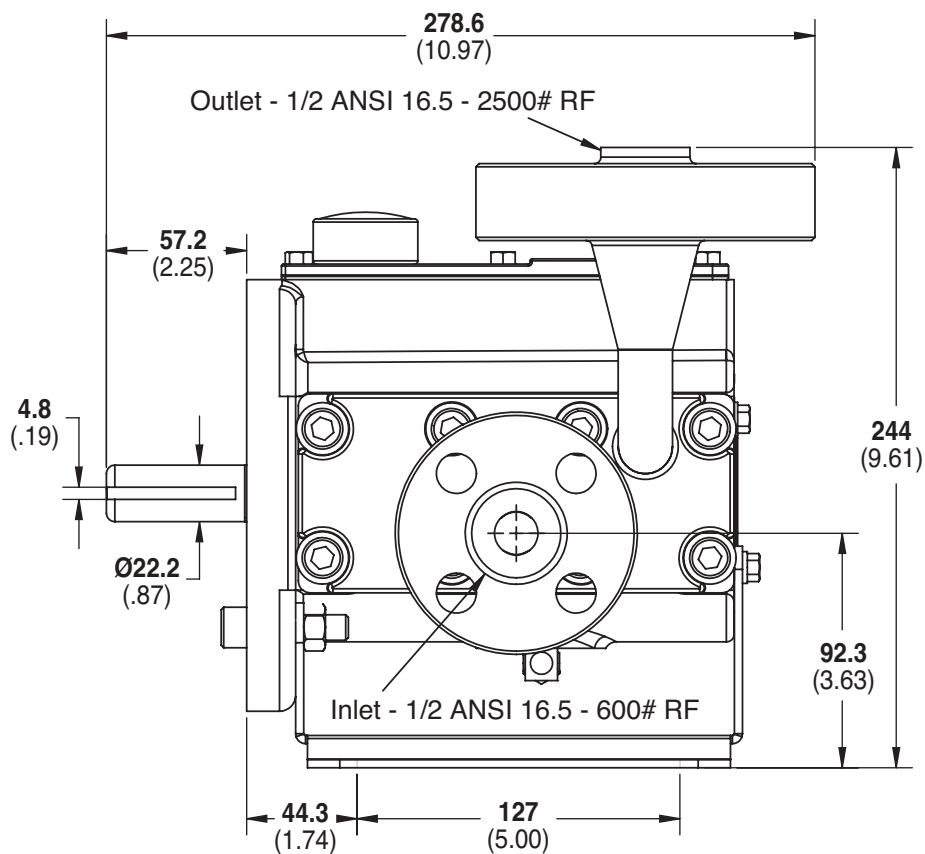
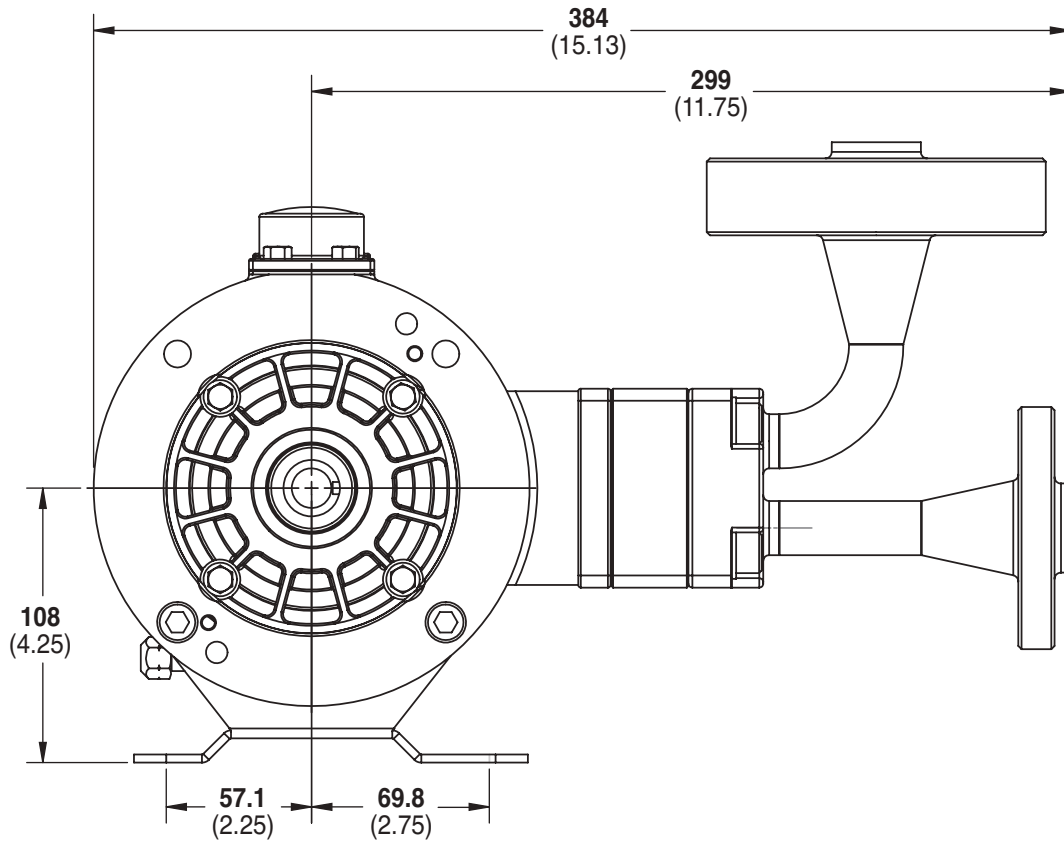

Note: Dimensions are for reference only. Contact factory for certified drawings.

Pump/Motor Adapter mm (Inches)

Part Number: A04-003-1202

Must be ordered separately for G04 models for use with IEC 80 - 90 frame motors, B5 flange.

NEMA adaptor available - consult factory.

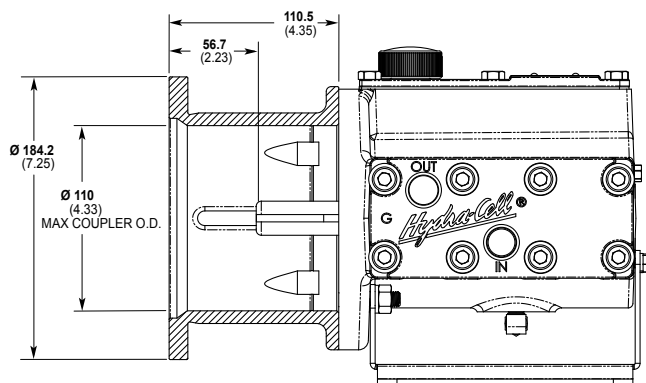

Part Number: A04-004-1202

Must be ordered separately for G04 models for use with IEC 100 - 112 frame motors, B5 flange.

NEMA adaptor available - consult factory.

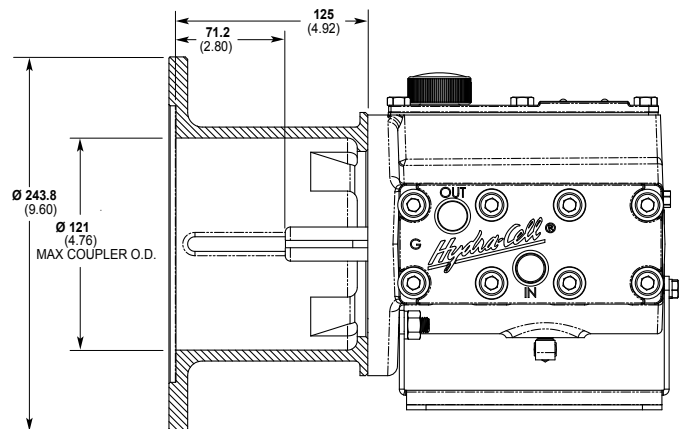

Valve Selection

A seal-less **C62 Pressure Regulating Valve** is recommended for Hydra-Cell G04 pumping systems, especially for high-pressure requirements or when handling dirty fluids.



G04 Pro Series | Options

Contact Wanner International for:

- Motors, bases, couplings and other pump accessories
- Hydra-Oil selection and specification information
- Design considerations, installation guidelines, and other technical assistance in pump selection
- Process liquid end built with NACE and 3.1 traceable material certification



G04 with Stainless Steel pump head



G04 with Brass pump head

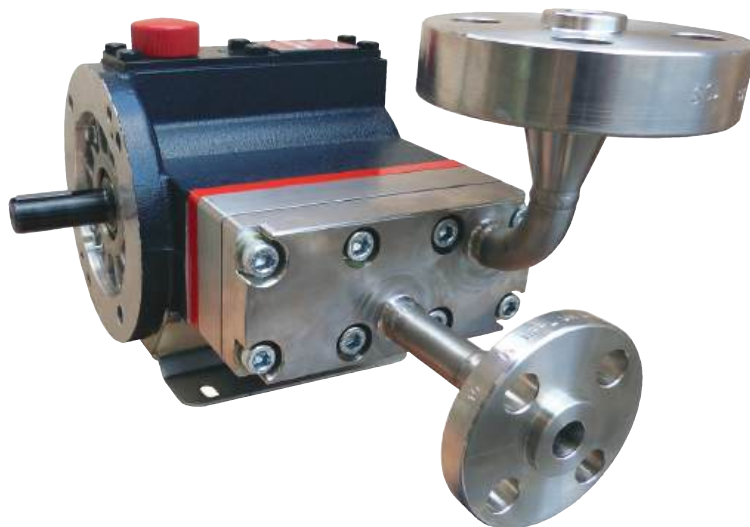

G04 with Stainless Steel pump head and ANSI RF flanges.

Ordering Information

A complete G04 Series Model Number contains 12 digits including 9 customer-specified design and materials options, for example: G04SABTHFECG.

1	2	3	4	5	6	7	8	9	10	11	12
G	0	4		D							

Digit	Order Code	Description
1-3		Pump Configuration
	G04	Shaft-driven (BSPT Ports or ANSI Flanges)* *Pump/motor adaptors ordered separately. See page 8.
4		Hydraulic End Cam
	X	Max 9.28 l/min (2.45 USgpm) @ 1450 rpm
	E	Max 6.38 l/min (1.74 USgpm) @ 1450 rpm
5		Pump Head Version
	D	BSPT Ports <i>See lower right for ATEX Certification Kit Options.</i>
6		Pump Head Material
	B	Brass
	S	316L Stainless Steel
	R	316L Stainless Steel with ANSI RF Flanges, Class 600lb x 2500lb
	-	316L Stainless Steel with DIN Flanges, Class PN40 DN20 x PN100 DN15♦
	T	Hastelloy CW12MW ♦ Selecting this option will result in a Wanner International generated Pump Code, stamped onto the pump.
7		Diaphragm & O-ring Material
	E	EPDM (requires EPDM-compatible oil - Digit 12 oil code C)
	G	FKM
	J	PTFE
	P	Neoprene
	T	Buna-N
8		Valve Seat Material
	D	Tungsten Carbide
	H	17-4 Stainless Steel
	N	Nitronic 50
	T	Hastelloy C

Digit	Order Code	Description
9		Valve Material
	D	Tungsten Carbide
	F	17-4 Stainless Steel
	N	Nitronic 50
	T	Hastelloy C
10		Valve Springs
	E	Elgiloy
	T	Hastelloy C
11		Valve Spring Retainers
	C	Celcon
	H	17-7 Stainless Steel
	M	PVDF
	P	Polypropylene
	T	Hastelloy C
	Y	Nylon
12		Hydra-Oil
	G	5W30 cold-temp severe-duty synthetic oil
	J	20-wt EPDM-compatible oil
	K	Food-contact oil



ATEX Certification Kit Options

As a separate line on your order, please add the required ATEX Certification Kit Option.

– ATEX 2014/34/EU Certified, Category 2, Zone 1

– ATEX 2014/34/EU Certified, Category 3, Zone 2

- All options include Certificate, Oil Level Monitor or Sight Glass, Earth Stud & Secondary ATEX Label.
- Extra oil is required to fill the oil bowl during installation of ATEX pumps. This oil is not included and must be ordered separately.

Partners in over 70 countries



WANNER™
Global Sales and Technical Support



Americas

-  Minneapolis, Minnesota USA
-  Wichita Falls, Texas USA
-  São Paulo, Brazil
-  Buenos Aires, Argentina





EMEA | Australia

-  Hampshire, United Kingdom
-  Cairo, Egypt
-  Düsseldorf, Germany
-  Lyon, France

Asia | Pacific

-  Kowloon, Hong Kong
-  Shanghai, China
-  Jakarta, Indonesia

India

-  Mumbai, India
-  New Delhi
-  Bangalore
-  Gujarat

Wanner worldwide

GLOBAL SALES & TECHNICAL SUPPORT

WANNER ENGINEERING, INC.

WORLD HEADQUARTERS & MANUFACTURING

Minneapolis, Minnesota USA
t: 612-332-5681
e: sales@wannereng.com
Hydra-Cell.com

REGIONAL OFFICE

Wichita Falls, Texas USA
t: 940-322-7111
e: sales@wannereng.com

LATIN AMERICAN OFFICE

São Paulo, Brazil
t: +55 (11) 99582-1969
e: mmagoni@wannereng.com
Hydra-Cell-Pumps.com.br

WANNER INTERNATIONAL, LTD.

UNITED KINGDOM

Church Crookham, Hampshire UK
t: +44 (0) 1252 816847
e: support@wannerint.com
Hydra-Cell.co.uk

WANNER PUMPS, LTD.

Kowloon, HONG KONG
t: +852 3428 6534
e: sales@wannerpumps.com
WannerPumps.com

Shanghai, CHINA
t: +86-21-6876 3700
e: sales@wannerpumps.com
WannerPumps.com

WANNER INDIA PVT. LTD.

Mumbai, INDIA
t: +91 (22) 22044766
e: support@wannerindia.com
WannerIndia.com



OFFICIAL UK DISTRIBUTOR

Michael Smith Engineers Limited
Web: www.michael-smith-engineers.co.uk
Email: info@michael-smith-engineers.co.uk
Freephone: 0800 316 7891