

MT8 PRO SERIES (ATEX) LOW PRESSURE METERING

Maximum Flow Rate: 30.28 L/hr (8.00 US gph)
Minimum Flow Rate: 0.227 L/hr (0.06 US gph)
Maximum Pressure: 103 bar (1500 psi) for
Metallic Pump Heads

WANNER™ HYDRA-CELL® PRO METERING PUMP SOLUTIONS

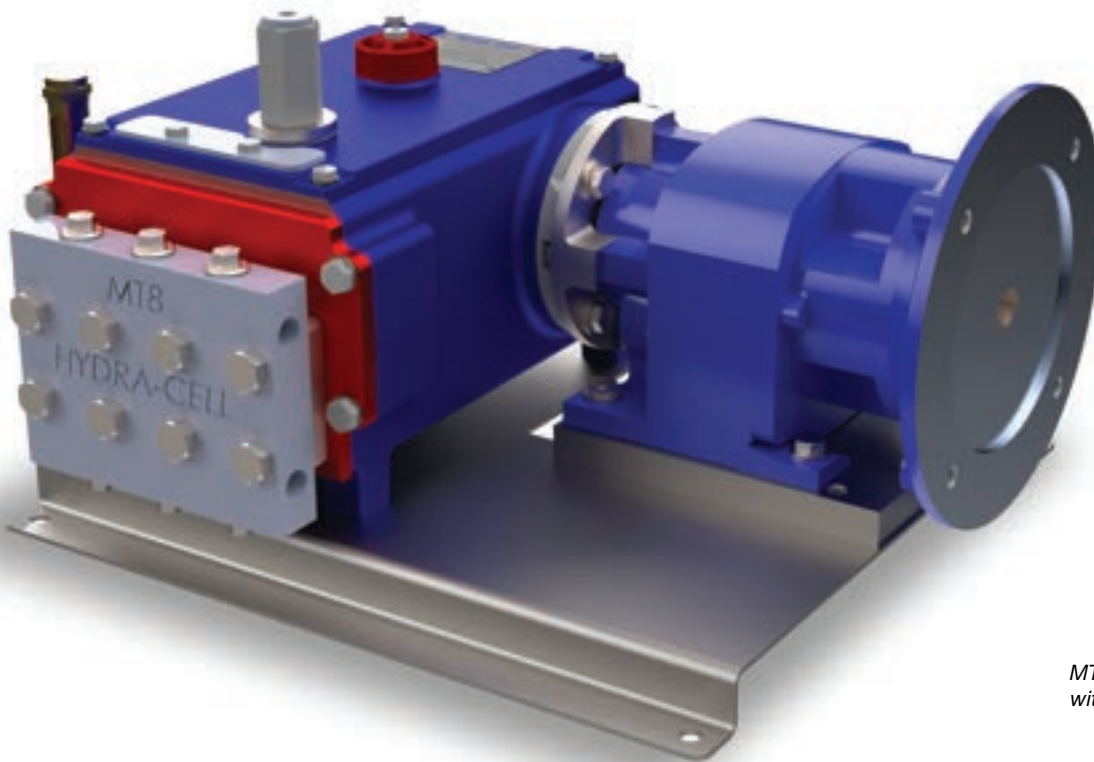

*MT8 Low Pressure Metering Pump
with Stainless Steel pump head for
use in ATEX/hazardous areas.*

A higher standard of metering performance and energy efficiency.

- ATEX Zone 1 IIC T4 (dependant on pump configuration).
- Integrates **Wanner Hydra-Cell® Pro** seal-less pump technologies for the highest levels of volumetric and energy efficiencies across the full turndown – from 100% to 1% of rated flow – for accurate metering performance.
- Multiple diaphragms deliver a very low-pulse flow, eliminating pulsation dampeners and pipe strain in most applications, with reduced acceleration head losses and a wider process window.
- Patented ADPC (Advanced Diaphragm Position Control) protects diaphragms under closed or restricted inlet conditions.
- Exceeds API 675 standards for steady-state accuracy ($\pm 1\%$), linearity ($\pm 3\%$), and repeatability ($\pm 3\%$) over a wide adjustable range.
- Hydraulic oil management system replenishes on every back stroke, ensuring superior accuracy and reliable operation at low- and high-suction pressures.
- Valve set design and material options reliably handle a wide range of viscosities and shear sensitivities, plus corrosive liquids, abrasives, slurries and suspended solids.
- Pumped liquid is 100% contained, preventing degradation and contamination.
- Reduced ownership costs in acquisition, operation, service, maintenance and energy use – with a 20+ year design life.



MT8 Pro Low Pressure (ATEX) | Performance

Maximum Flow at Designated Pressure

for Pumps with Gearbox Reducer

For Synchronous Speed, Self-cooled Motors

Liters per Hour (L/hr) Maximum Flow at Designated Pressure

All Pumps in Liters per Hour (L/hr)			Pump rpm	Gear Ratio	Motor rpm
24 bar	34 bar	103 bar			
1.79**	1.79**	1.62**	18.42	81.45	1500
2.71	2.70	2.44	27.76	54.03	
3.53	3.53	3.18	36.27	41.36	
4.72	4.70	4.25	48.39	31.00	
7.18	7.16	6.46	73.64	20.37	
14.93	14.89	13.44	153.22	9.79	
20.65	20.59	18.59	211.86	7.08	
31.64*	31.56*	28.49	324.68	4.62	
38.57*	38.47*	34.73*	395.78	3.79	

Required Motor kW	Motor frame
0.12	IEC 63, B5
0.18	IEC 63, B5
0.25	IEC 71, B5

For 10:1 Turndown, Self-cooled Motors

Liters per Hour (L/hr) Maximum Flow at Designated Pressure

All Pumps in Liters per Hour (L/hr)			Pump rpm	Gear Ratio	Motor rpm
24 bar	34 bar	103 bar			
1.79**	1.79**	1.62**	18.42	81.45	1500
2.71	2.70	2.44	27.76	54.03	
3.53	3.53	3.18	36.27	41.36	
4.72	4.70	4.25	48.39	31.00	
7.18	7.16	6.46	73.64	20.37	
14.93	14.89	13.44	153.22	9.79	
20.65	20.59	18.59	211.86	7.08	
31.64*	31.56*	28.49	324.68	4.62	
38.57*	38.47*	34.73*	395.78	3.79	

Required Motor kW	Motor frame
0.12	IEC 63, B5
0.18	IEC 63, B5
0.25	IEC 71, B5

Please Note: Systems vary. The MT8 pump must be calibrated once installed to ensure optimum performance. The API 675 Performance Standard is achievable for flow rates as low as 0.227 L/hr (0.06 US gph). Please contact Wanner for assistance.

* Flow rates above 30.28 lph are not guaranteed to meet API 675 Performance Standards.

** Please consult Wanner for higher ratio gearboxes and flows below 2.2 L/hr.

Notes:

- The motor kW are based on ambient temperature conditions up to 25°C. For ambient temperatures above 25°C, Force-cooled Motors may be required. Please contact Wanner International.
- Contact Wanner for performance specifications.
- Based on using IE3 motors.
- Maximum continuous motor speed is 1500 rpm at full pressure.
- For intermittent or reduced pressure duties, please contact Wanner International.

Manual Adjustment Controller

All Min/Max flow rates in Liters per Hour (L/hr)

24 Bar		34 Bar		103 Bar		Max Pump RPM	Required Motor kW and Frame Sizing
Min	Max	Min	Max	Min	Max		
0.23	38.00	0.23	37.91	0.23	34.22	390	0.37kW / IEC80 / B14 / 6-pole

For MT8 direct coupled to manual adjustment controller, without gearbox.

Due to the Wanner Engineering Continuous Improvement Program, specifications and other data are subject to change.

MT8 Pro Low Pressure (ATEX) | Features & Specifications

Pump Features

- Patented ADPC – Advanced diaphragm position control. Protects the diaphragms from adverse suction conditions.
- Can run dry indefinitely without damage to the pump.
- Wide, controllable flow range Independent of discharge pressure – from 100% to 1% of rated flow.
- Easy pump control eliminates mechanical actuators.
- Patented hydraulic replenishment systems replenishes on every diaphragm back stroke ensuring accurate consistent displacement on every forward stroke.
- Low shear pumping action.
- Internal pressure relief valve to protect the pump.
- Constant diaphragm stroke length ensures accurate control of flow rate with turn downs higher than 10:1
- Many materials of construction, easy change of parts makes pump repurposing easy.
- Compact design with oil management system and multiple diaphragms in a single pump head – reduces size and weight.
- Simple servicing, no special tools or equipment needed.
- Robust 20+ year service life with minimal maintenance.

Pump Data

Diaphragms per Liquid End	3
Flow Control	Electronic variable speed drive
Maximum Discharge Pressure	
Metallic Heads:	103 bar (1500 psi)
Maximum Inlet Pressure	
Metallic Heads:	34 bar (500 psi)
Operating Temperatures (min./max.)	
Metallic Heads:	4.4°C (40°F) to 121°C (250°F)
<i>Consult Wanner for temperatures outside this range</i>	
Inlet Port	1/4 inch NPT or BSPT
Diaphragm Material Temperatures (min./max.)	
	4.4°C (40°F) to 121°C (250°F)
Discharge Port	1/4 inch NPT or BSPT
Maximum Solids Size	200 microns
Shaft Rotation	Bi-directional
Oil Capacity	1.7 liters (1.75 US quarts)
Suction Lift Capability	6.1 meters (20 feet)
Weight (less motor)	
Metallic Heads:	36 kg (80 lbs.)

MT8 Low Pressure
Component Identification

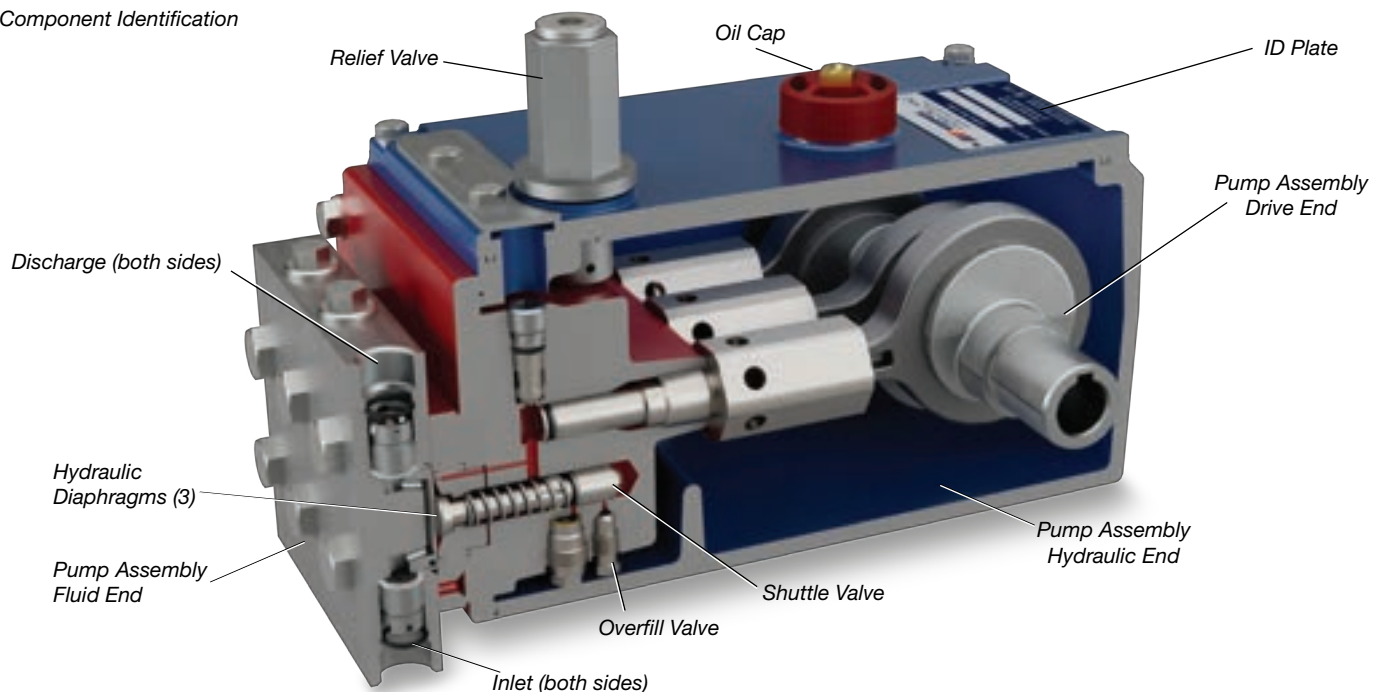

Due to the Wanner Engineering Continuous Improvement Program, specifications and other data are subject to change.

MT8 Pro Low Pressure (ATEX) | Representative Drawings

Metallic Pump Heads Inches (mm)

**MT8 Pro Low Pressure (ATEX)
with Manual-Adjust**

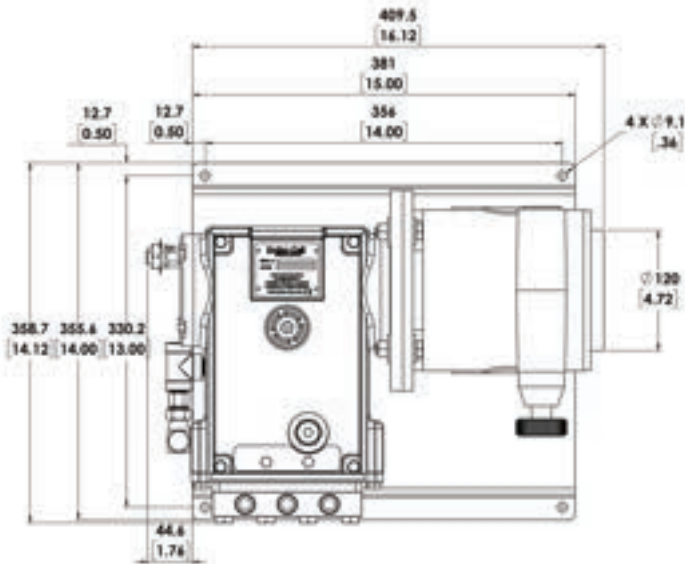

**MT8 Pro Low Pressure (ATEX)
with Fixed-Ratio Gearbox**

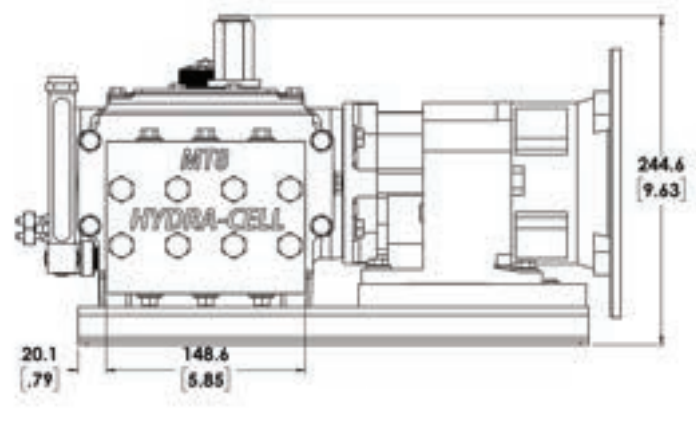
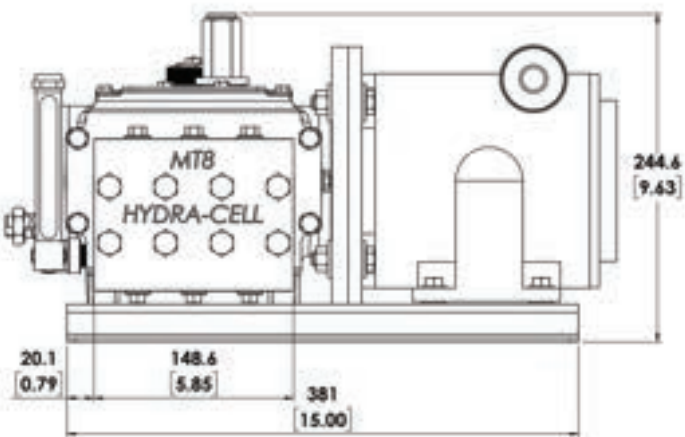
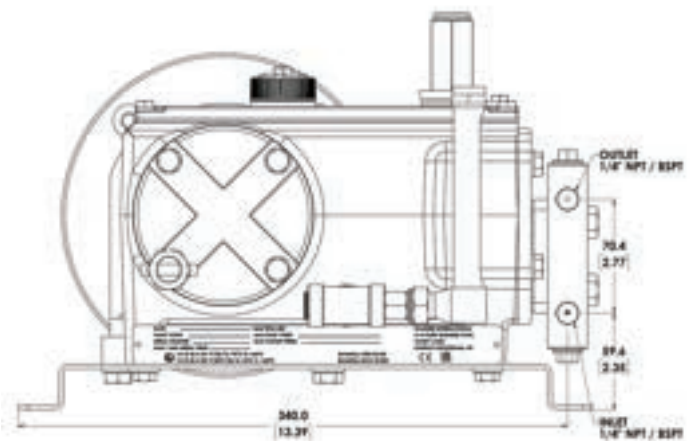
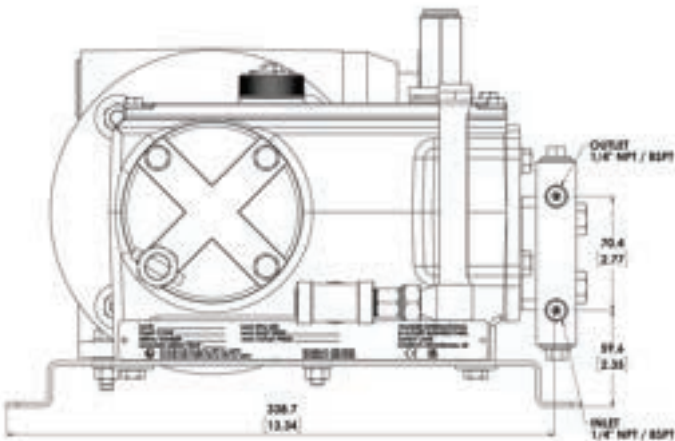
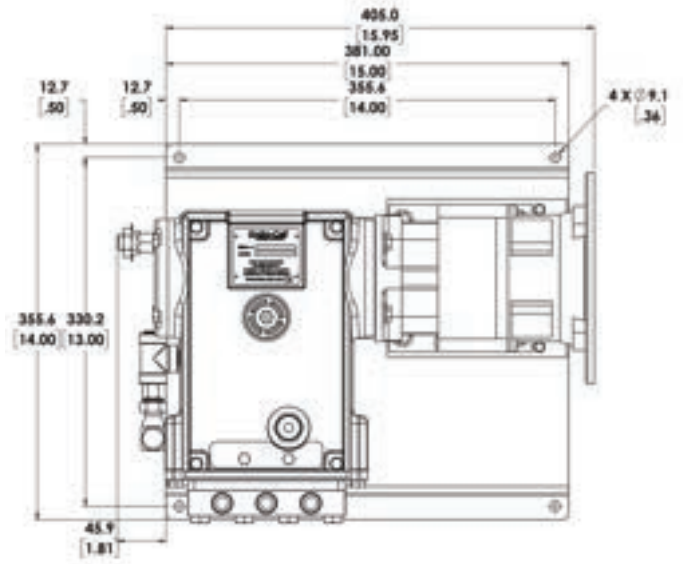

Note: Dimensions are for reference only. Contact Wanner for certified drawings.

MT8 Pro Low Pressure (ATEX) | Representative Drawings

Metallic Pump Heads Inches (mm)

MT8 Pro Low Pressure (ATEX) Solution for Local and Remote Control

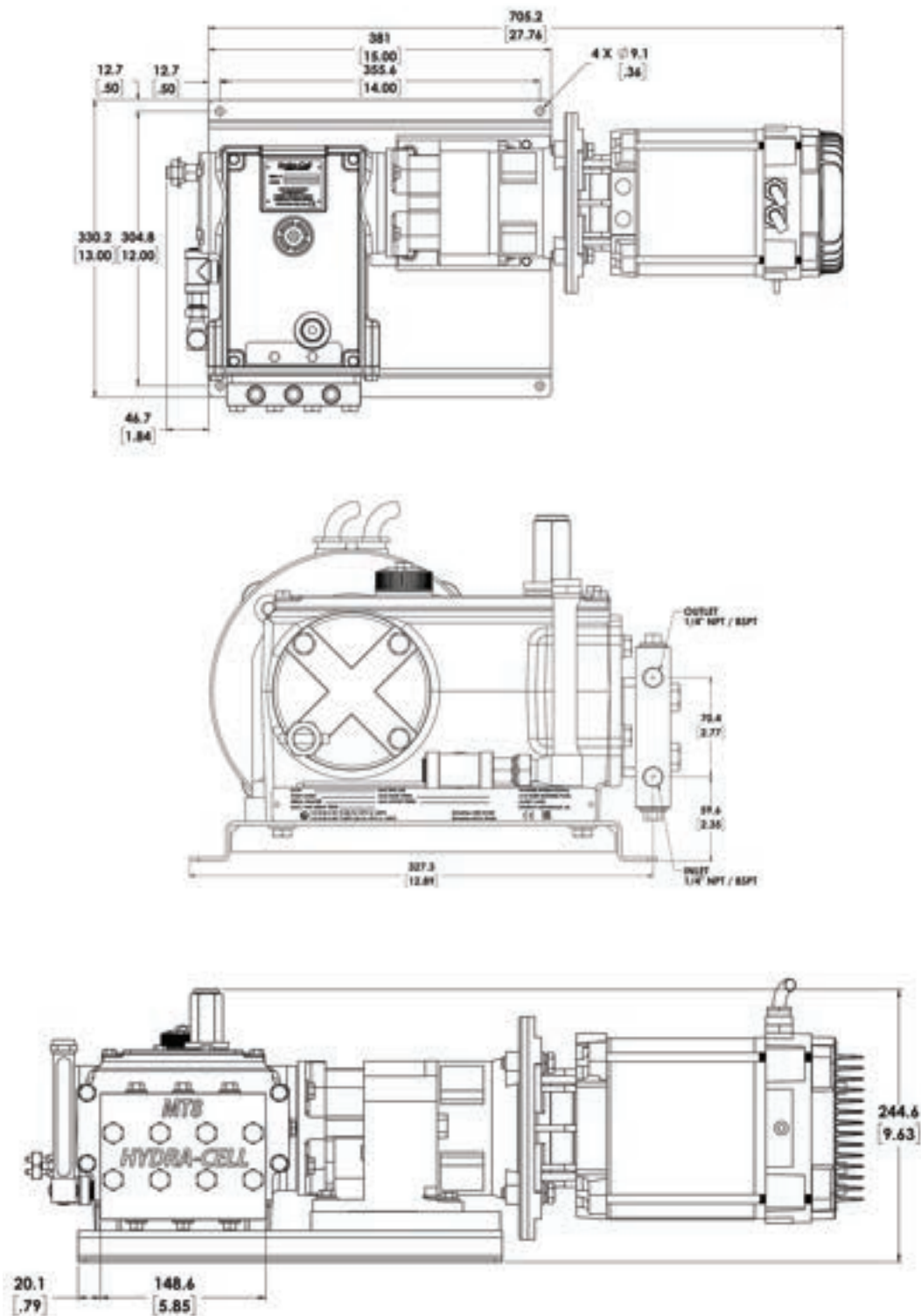

Note: Dimensions are for reference only. Contact Wanner for certified drawings.

Metering and Dosing Control Options for use in ATEX/hazardous areas

Electronic Flow Rate Adjustment Solution for Local or Remote Control

- Quick and precise flow rate control with versatile configurations
- High efficiency and reliability for heavy duty usage; up to 1500 rpm
- Remote control via 4-20mA input signal
- Local speed control via rotary potentiometer
- ATEX Zone 1 IIB T4

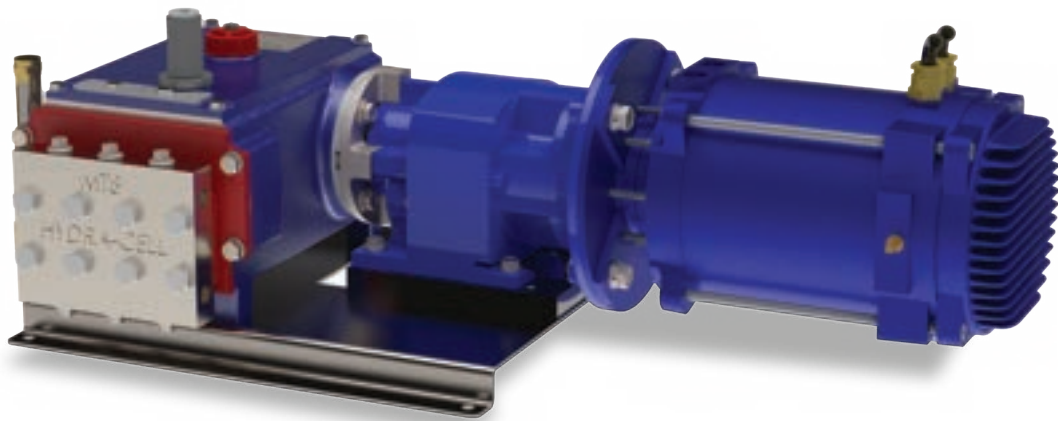

Manual Flow Rate Adjustment for Local Control

- Linear fine adjustment scale on hand-wheel
- High reliability due to frictionless design
- Option to fit a mechanical lock to prevent unauthorised flow rate change
- ATEX Zone 1 IIC T4

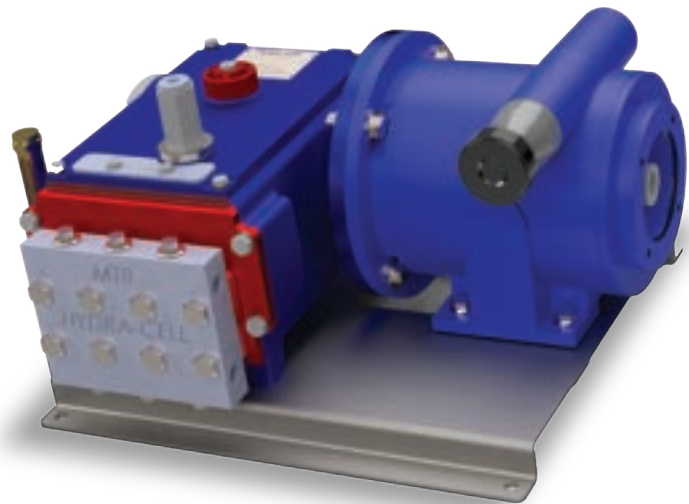

Accessories, Options & Services

Consult Wanner International for complete details about available accessories and options as well as special services.

- Different Gearbox Ratios
- Actuating Oils
- Magnetic Drain Plug
- Motors (ATEX certified)
- Calibration Cylinders
- Back Pressure Valves
- Pressure Relief Valves
- API 675 Performance Test Certificate
- System Components, Priming Kits and Plugs
- Replacement Part Kits and Tool Kits
- Pulsation Dampeners
- Customisation Services

MT8 Pro Low Pressure (ATEX) | How to Order

Ordering Information

A complete pump order number contains 18 digits based on the specified pump materials listed below:

1	2	3	4	5	6	7	8	9	10	11	12	13	14	15	16	17	18
M	T	0	8		S	N	J	N	S	S					T	L	

Digit	Order Code	Description
1-2	MT	Pump Model Size Triplex Metering Pumps
3-4	08	Pump Capacity 0.227 – 30.28 L/ph (0.06 – 8.00 US gph)
5	B F	Pump Version NPT Ports; ATEX Zone 1 BSPT Ports; ATEX Zone 1
6-7	SN	Pump Head 316 SST
8	J	Diaphragm PTFE
9	N	Leak Detection Style No leak detection
10-11	SS	CV Ball/Seat 316 SST / 316 SS
12	B G K	Hydraulic End Oil EPDM oil (NSF H1 accredited) 5W30 (Synthetic oil) Food-contact oil (NSF H1 accredited)
13	C D E M	Motor Flange Size IEC 63 B5 IEC 71 B5 IEC 80 B5 IEC 80 B14 (MX only)

Digit	Order Code	Description
14-15		Gearbox Ratio
	81	81.45:1
	54	54.03:1
	41	41.36:1
	31	31.00:1
	20	20.37:1
	10	9.79:1
	07	7.08:1
	05	4.62:1
	04	3.79:1
	MX	Manual adjustment ATEX (specify M flange for this option)
16	T	Baseplate SST
17	L	Maximum Pressure Rating Low Pressure 103 bar (1500 psi) Max Discharge
18	L R X	Electronic Flow Rate Adjustment Solution Local speed control rotary potentiometer* Remote control 4-20mA input signal* Not Required**

* Digit 18 options L and R: ATEX Zone 1 IIB T4

** Digit 18 option X: ATEX Zone 1 IIC T4

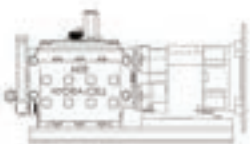

MT8 Pro Low Pressure (ATEX) with fixed ratio gearbox:

Select configuration from digits 1-18.
Do not select "M" (digit 13).
Do not select "MX" (digits 14-15).

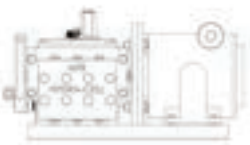

MT8 Pro Low Pressure (ATEX) with manual adjust gearbox:

Select configuration as required digits 1-18.
Select "M" (digit 13).
Select "MX" (digits 14-15).

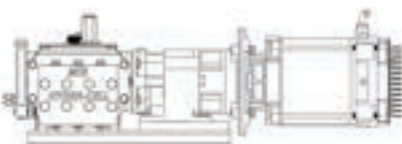

MT8 Pro Low Pressure (ATEX) solution for local and remote control:

Select configuration as required digits 1-18.
Select "E" (Digit 13).
Do not select "MX" (digits 14-15).
Select configuration as required for digit 18.

Partners in over 70 countries



Global Sales and Technical Support

Americas

- Minneapolis, Minnesota USA
- Wichita Falls, Texas USA
- São Paulo, Brazil
- Buenos Aires, Argentina

EMEA | Australia

- Hampshire, United Kingdom
- Cairo, Egypt
- Düsseldorf, Germany
- Lyon, France

Asia | Pacific

- Kowloon, Hong Kong
- Shanghai, China
- Jakarta, Indonesia

India

- Mumbai, India
- New Delhi
- Bangalore
- Gujarat

Wanner worldwide

GLOBAL SALES & TECHNICAL SUPPORT

WANNER ENGINEERING, INC.

WORLD HEADQUARTERS & MANUFACTURING

Minneapolis, Minnesota USA
t: 612-332-5681
e: sales@wannereng.com
Hydra-Cell.com

REGIONAL OFFICE

Wichita Falls, Texas USA
t: 940-322-7111
e: sales@wannereng.com

LATIN AMERICAN OFFICE

São Paulo, Brazil
t: +55 (11) 99582-1969
e: mmagoni@wannereng.com
Hydra-Cell-Pumps.com.br

WANNER INTERNATIONAL, LTD.

UNITED KINGDOM

Church Crookham,
Hampshire UK GU52 8BF
t: +44 (0) 1252 816847
e: support@wannerint.com
Hydra-Cell.co.uk

WANNER PUMPS, LTD.

Kowloon, HONG KONG
t: +852 3428 6534
e: sales@wannerpumps.com
WannerPumps.com

Shanghai, CHINA
t: +86-21-6876 3700
e: sales@wannerpumps.com
WannerPumps.com

WANNER INDIA PVT. LTD.

Mumbai, INDIA
t: +91 (22) 22044766
e: support@wannerindia.com
WannerIndia.com



**OFFICIAL UK
DISTRIBUTOR**

Michael Smith Engineers Limited
Web: www.michael-smith-engineers.co.uk
Email: info@michael-smith-engineers.co.uk
Freephone: 0800 316 7891

